

VELSANET

Architecture Compendium

- #01 Network Architecture Overview
- #02 Wired-Wireless Convergence
- #03 Multi-Optical-Core Transceiver
- #04 Matrix Architecture
- #05 Spatial Genesis
- #06 Multimodal Cube Architecture
- #07 Mathematical Framework
- #08 AI Architecture
- #09 Three-Layer AI System
- #10 Network AI
- #11 IVGF Conceptual Existence
- #12 Foundation Architecture
- #13 Node Color Semantics
- #14 City E2E Management Center
- #15 Identity & Path Authority
- #16 Path Formation
- #17 Path Lifecycle
- #18 Network AI & Global Governance
- #19 Cognition Cube System
- #20 Node Intelligence & Optical Parallelism
- #21 AI Safety by Architecture
- #22 H6-Based 6G RAN Architecture
- #23 6G RU: Multi-User Physical Mapping ★**

Velsanet Architecture Compendium v2.4 | 260308 | 23 White Papers

github.com/joa337/velsanet-whitepapers

Table of Contents

01. Velsanet Network White Paper
02. Velsanet Wired-Wireless Convergence White Paper
03. Velsanet Multi-Optical-Core Transceiver (MOCT) White Paper
04. Velsanet Matrix Architecture White Paper
05. Velsanet Spatial Genesis White Paper
06. Velsanet Multimodal-to-Cube Memory Architecture White Paper
07. Velsanet Mathematical White Paper
08. Velsanet AI White Paper
09. Velsanet Three-Layer AI System White Paper
10. Velsanet Network AI White Paper
11. IVGF Conceptual Existence White Paper
12. Velsanet Foundation White Paper
13. Velsanet Node Color White Paper
14. Velsanet City-level E2E Management Center White Paper
15. Velsanet Identity White Paper
16. Velsanet Path Formation White Paper
17. Velsanet Path Lifecycle White Paper
18. Velsanet Network AI and Global Governance Architecture White Paper
19. Velsanet Cognition Cube System White Paper
20. Velsanet Node Intelligence and Optical Parallelism White Paper
21. Velsanet AI Safety by Architecture White Paper
22. Velsanet H6-Based 6G RAN Architecture White Paper
- 23. Velsanet 6G RU: Multi-User Physical Mapping White Paper ★ NEW**

Velsanet Architecture Compendium v2.4 | 260308 | 23 White Papers | github.com/joa337/velsanet-whitepapers

No. 01

Velsanet Network White Paper

01

Velsanet: Next-Generation 3D Distributed Network and AI Integration Strategy

1. Introduction

The meaning of connection is changing.

Networks are no longer just channels for data — they are becoming spaces where intelligence flows.

Velsanet envisions a network that senses, understands, and evolves through interaction.

Built on a 3D polyhedral distributed structure, it integrates AI into every layer,

allowing information to move with **intent** rather than simple transmission.

Each node participates in a larger **collective intelligence**,

creating a network that grows and adapts like a living system.

2. Concept and Vision of Velsanet

Figure: 2.1 Limitations of Existing Networks and the Need for Velsanet

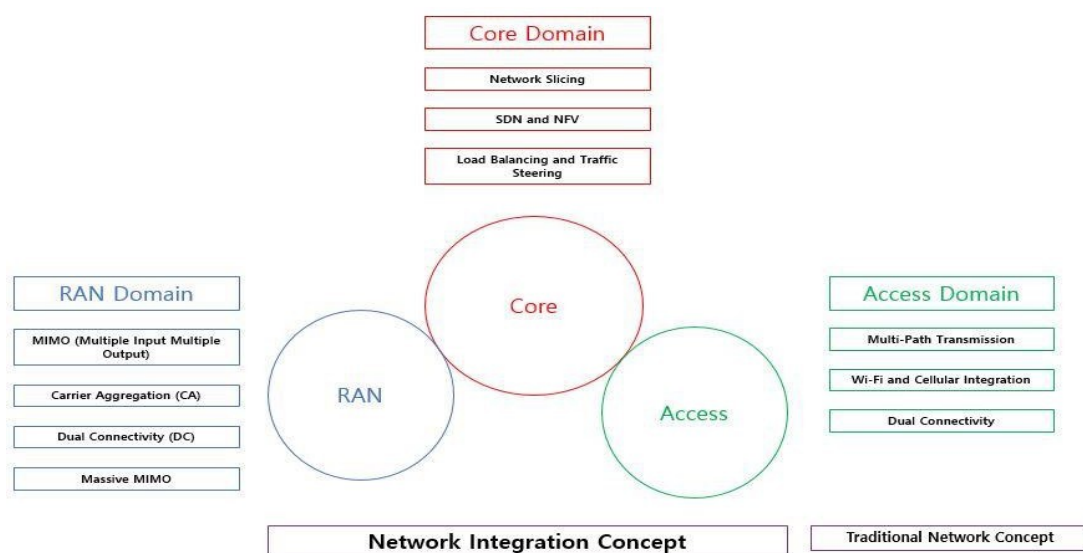

2.1 Limitations of Existing Networks and the Need for Velsanet

Modern internet infrastructure is optimized for data transfer but lacks the ability to interpret **meaning and intent**.

As IoT and streaming technologies accelerate, data traffic surges, latency issues persist, and management grows increasingly complex.

Beyond technical limitations, this reveals a deeper gap — the network fails to carry **human intent or AI cognition** within its flow.

Thus, the next-generation network must evolve from being **data-centric** to **intent-centric**.

Key Limitations:

- **Traffic Explosion:** Overload caused by IoT, video, and streaming data
- **Latency & Instability:** Degraded quality of real-time services
- **Management Complexity:** Diverse protocols and devices reduce efficiency
- **Intent Gap:** Human and AI objectives are not embedded in data transmission

Figure: 2.2 Core Philosophy of Velsanet

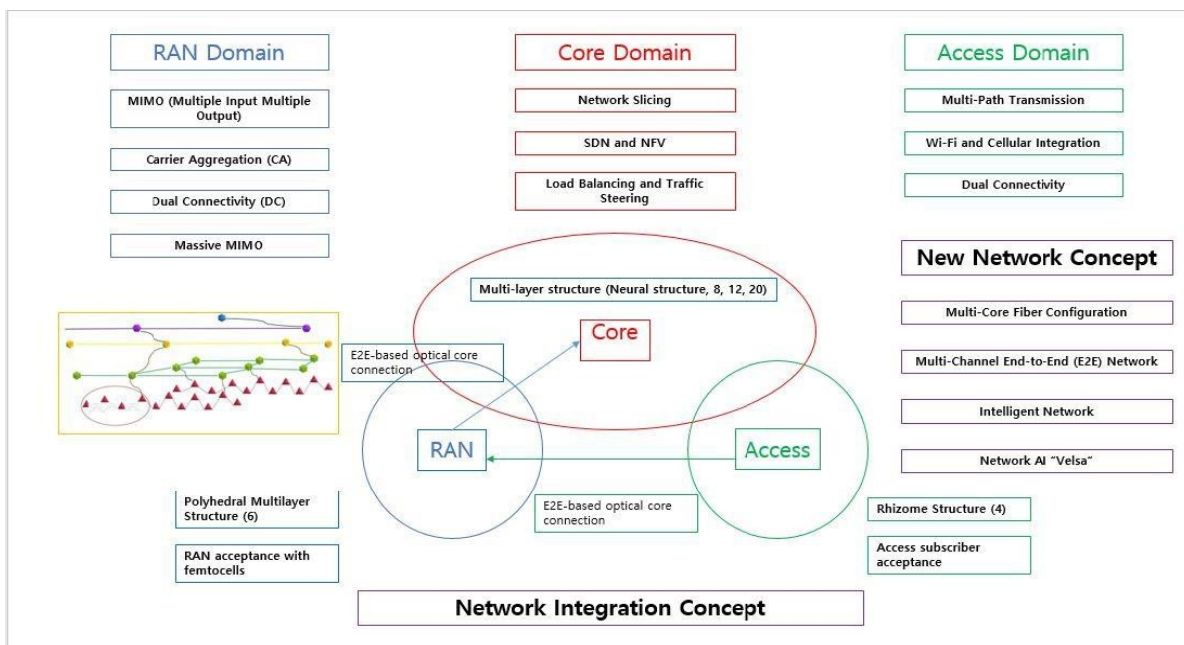

2.2 Core Philosophy of Velsanet

Velsanet envisions the network not as a static communication tool, but as a **living intelligent ecosystem**.

Each node acts as a **unit of intent**, interacting with others to form **collective intelligence**.

This architecture, built upon a polyhedral 3D distributed structure, enables the network to exchange not only data but **meaning and purpose**.

Through this, Velsanet establishes a framework where intelligence flows naturally across layers,

allowing the system to **think, learn, and grow organically**.

It represents a new paradigm where humans, AIs, and systems evolve together through shared intent and adaptive cooperation.

Core Principles:

- **Integration & Scalability:** Unified management of diverse devices and services
- **Flexible Structure:** 3D polyhedral design for horizontal and vertical expansion
- **Intelligent Management:** AI-based autonomous optimization
- **Multi-Optical-Core E2E:** Direct, parallel user-service connections
- **Independence from the Internet:** Operates as a self-contained network
- **Intent-Driven Networking:** Connections based on meaning, not just data
- **Collective Intelligence & Organic Growth:** A network that evolves like a living organism

3. Technical Structure of Velsanet

3.1 Polyhedron-Based Network Structure

- **Node Design**
 - **Variety of Polyhedra:** Each node takes various polyhedron forms such as tetrahedron (4 faces), cube (6 faces), octahedron (8 faces), dodecahedron (12 faces), and icosahedron (20 faces).
 - **Modular Composition:** Nodes are modularly designed for easy assembly and expansion as needed.
 - **Unique Identifier:** Each node has a unique identifier determining its position and role within the network.
- **Network Topology**
 - **Hierarchical Structure:** Nodes are arranged hierarchically based on physical location and function.
 - **Mesh Network:** Multiple connections between nodes enhance path diversity and stability.
 - **3D Scalability:** Supports both horizontal and vertical expansion to maximize space efficiency.
- **Node Structure and Function Overview**

Figure: 3.1a Overview of Polyhedron-Based Node Structures and Optical Cores





Node	Structure	Color	Optical Cores
Tetrahedron (4)	Access Network	Green 	8
Hexahedron (6)	RAN-Based Microcell	Yellow 	32
Octahedron (8)	Urban Network	Red 	192
Dodecahedron (12)	Regional Network	Blue 	1536
Icosahedron (20)	National Backbone Network	Purple 	18,432

Figure: 3.1b Functional Roles of Nodes in the Velsanet Network

Node	Function	Color	Optical Cores
Node_5	Regional Access Interconnection	Light Green 	20
Node_7	RAN & Regional Network	Orange 	112
Node_10	Urban Backbone Network	Sky Blue 	864
Node_16	National & Global Backbone	Gray 	9984

- **Horizontal Nodes (Optical Core Coordination within the Same Layer)**
 - **Role:** Manage parallel optical core connectivity within the same layer, preventing unnecessary bottlenecks and ensuring efficient data pathways.
 - **Scalability:** As the layers scale up, optical core density increases, expanding coverage.
- **Vertical Nodes (End-to-End Optical Core Connectivity)**
 - **Role:** Direct optical core connectivity between hierarchical layers for maximum performance, maintaining seamless communication across different network levels with guaranteed reliability.
 - **Elimination of Distributed Traffic Dependency:** Unlike traditional internet models, Velsanet eliminates distributed traffic dependency, ensuring more efficient data flow.
- **Velsanet Network Principles**
 - **Horizontal Coordination:** Horizontal nodes coordinate optical core connectivity within the same layer.
 - **Vertical Connectivity:** Vertical nodes establish hierarchical optical core connections, maintaining structural integrity.
 - **Optical Core Density:** Optical core density increases with node level, ensuring future scalability.
 - **Polyhedral Design:** The polyhedral design enhances the reliability and efficiency of next-generation networks.
 -
- **Future Scalability & Technological Advancements**
 - **Optical Cable Structures:** Optical cable structures do not support branching, preserving network consistency.
 - **Multi-Optical Transceivers:** The development of multi-optical transceivers optimizes optical core efficiency.
 - **Nano-Optical Cable Advancements:** Nano-optical cable advancements will drive the future of hyperconnected infrastructure.
 - **Cable Color Standards:** Defining cable colors and standards enhances real-world management and maintenance.
 - **Polyhedral Framework:** A polyhedral-based framework ensures an intuitive and streamlined education process.

0

- Figure: 3.1c: Velsanet Hierarchical Polyhedral Network Connection Concept

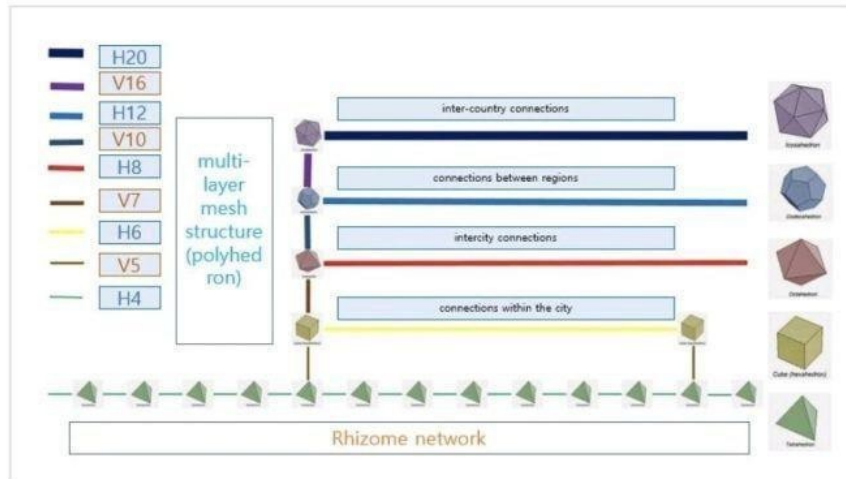

- Figure: 3.1d: Tetrahedral Equipment Concept Diagram - Shows a hexahedral structure connected with 20 optical cores and a tetrahedral structure connected with 8 optical cores.

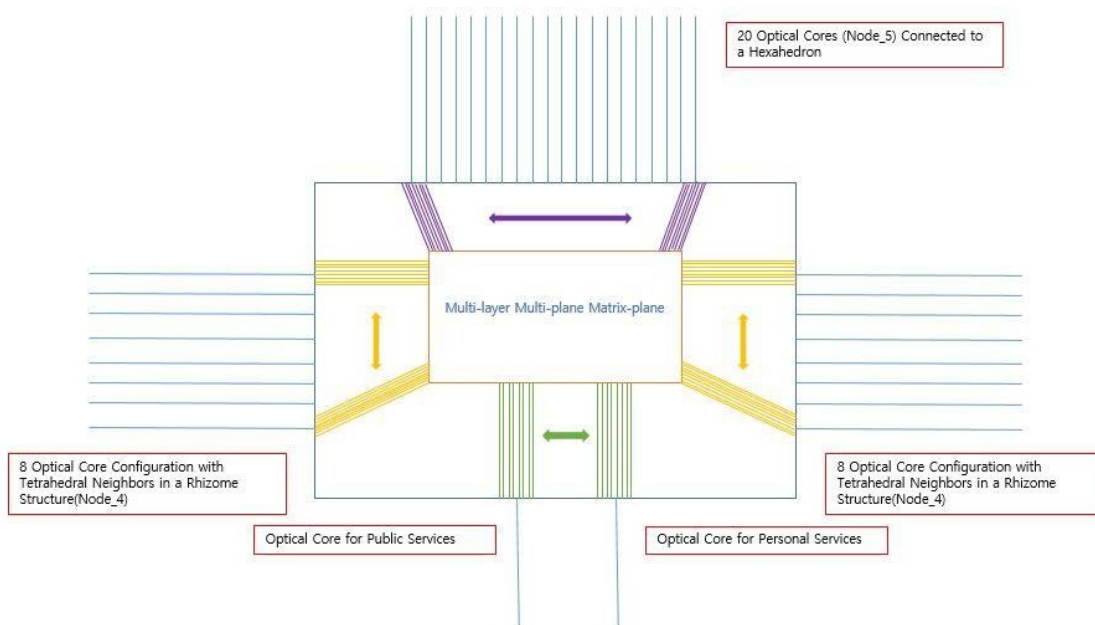
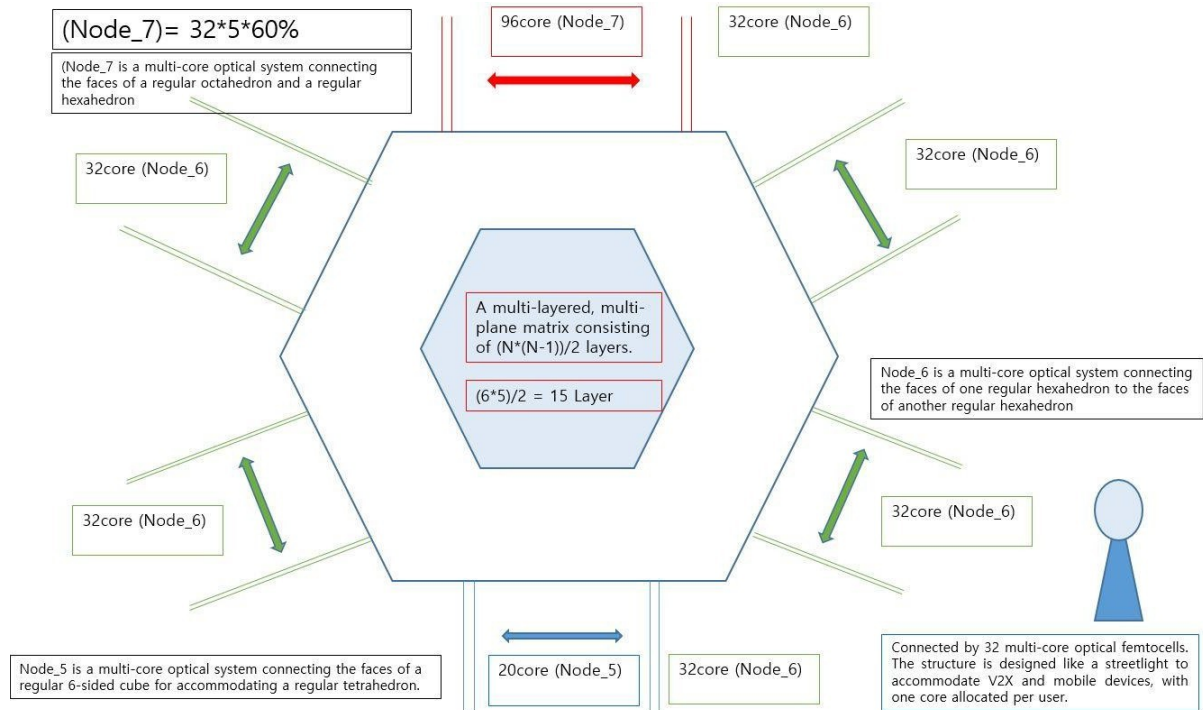

Figure: 3.1e: Hexahedral Equipment Concept Diagram – Shows a hexahedral device equipped with multi-core optical transceivers for parallel data transmission and hierarchical network connectivity.



3.2 Rhizome Network and Multidimensional Connections

- **Rhizome Network**
 - **Main Constituents: Union of Users:** Formed based on voluntary participation and collaboration of users, each acting as a node and member of the network.
 - **Decentralization:** Nodes are equally connected without a central hub.
 - **Organic Growth:** The network grows and expands autonomously like plant roots.
 - **Resilience:** The entire network operates unaffected even if specific nodes fail.

- **Multilayer Mesh Network**
 - **Main Constituents: Union of Service Providers:** Service providers collaborate to build and operate network infrastructure, including telecom companies and content providers.
 - **Hierarchical Structure:** Physical infrastructure and service layers are separated, each performing specialized functions.
 - **Multiple Path Settings:** Prevents network congestion through traffic distribution and alternative paths.
 - **Quality of Service Assurance:** Maintains high levels of QoS through cooperation among service providers.

- **Multidimensional Connections**
 - **Physical and Logical Connections:** Optimizes data transmission through mapping of interconnections

between individual channels.

- **Interaction between Users and Service Providers:** Supports smooth communication between users and service providers, with the Rhizome and multilayer mesh networks complementing each other.
-
- *Figure: 3.2 Velsanet Multi-Layer Multi-Plane Optical Network Architecture Diagram*

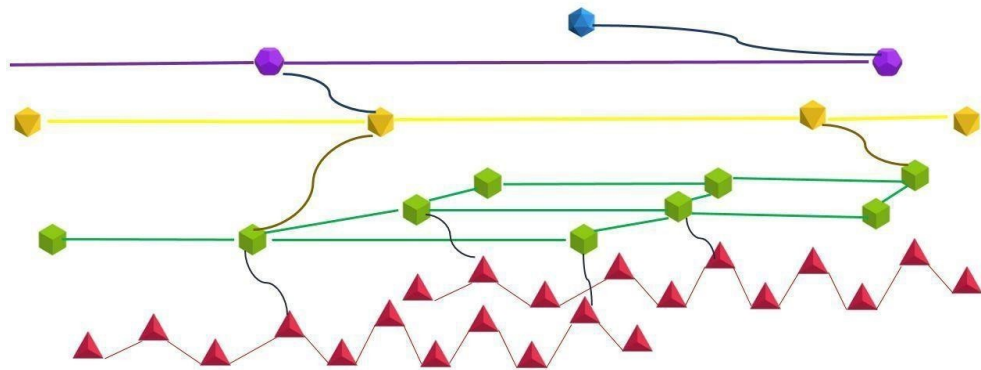

3.3 Multichannel Multimodal Communication System

- **Channel Structure**
 - **Multichannel Connections:** Structured with multichannel connections, without channel distinctions based on service types.
 - **Digital Signal Basis:** Accepts any form of signal capable of digital transmission.
 - **No Need for Frequency Bandwidth Management:** Efficient communication is possible without frequency bandwidth management through mapping interconnections of individual channels.
- **Acceptance of Femtocell-Based Mobile Communication Networks**
 - **Alignment of Wireless Multichannel and Wired Optical Core:** Integrates wireless multichannels with wired optical core multichannels to form a unified network.
 - **Implementation of a Global Single Telecom Operator:** Enables the world to implement services as a single telecom operator.
- **Multimodal Communication**
 - **Integration of Voice, Video, and Data:** Enhances user experience by simultaneously processing various forms of data.
 - **Real-Time Translation and Conversion:** Provides real-time conversion between different modalities using AI.
- **QoS (Quality of Service) Assurance**
 - **Intelligent Traffic Management:** Network AI analyzes and adjusts traffic in real-time.
 - **Maintenance of Service Quality:** Maintains high levels of service quality through efficient management of

individual channels.

- o
- *Figure: 3.3 Velsanet Optical Multilink and High-Speed Transceiver Configuration Diagram*

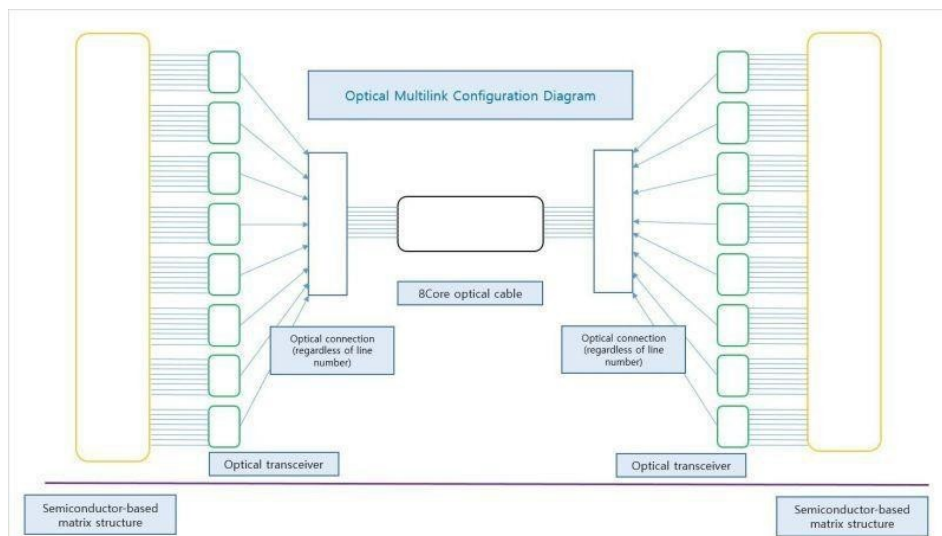

3.4 E2E Multichannel Intelligent Network

- **Strengthening** End-to-End Communication
 - o **Direct Connections:** Minimizes intermediate nodes or hubs to provide direct connections between users and services.
 - o **Reduction of Latency:** Minimizes communication delays by reducing unnecessary routing.
- **Multichannel** Basis
 - o **Parallel Data Transmission:** Maximizes bandwidth by transmitting data in parallel through multiple channels.
 - o **Connection through Channel Mapping:** Realizes efficient data transmission through mapping of interconnections between individual channels.
- **Intelligent** Network Management
 - o **Real-Time Optimization:** Optimizes network paths and resources in real-time using AI algorithms.
 - o **Prediction and Response:** Predicts traffic patterns and usage to respond proactively.

3.5 Fault Tolerance and Reduced Recovery Urgency

The Velsanet distributed network boasts strong **fault tolerance** via multiple paths:

- **Alternate Routes:** Traffic is automatically rerouted during failures, preventing complete service outages.
- **Low Recovery Urgency:** A single failure doesn't immediately disrupt overall operations, reducing the need for urgent repairs.
- **Timely Restoration:** While individual failures are non-critical,

prolonged issues can weaken redundancy, so swift repairs are still advisable.

- **Velsanet Philosophy:** Leveraging multiple parallel conduits and intelligent routing without a centralized hub ensures a stable and flexible network.

Figure: 3.5 New Fiber Optic Configuration & Conduit Design

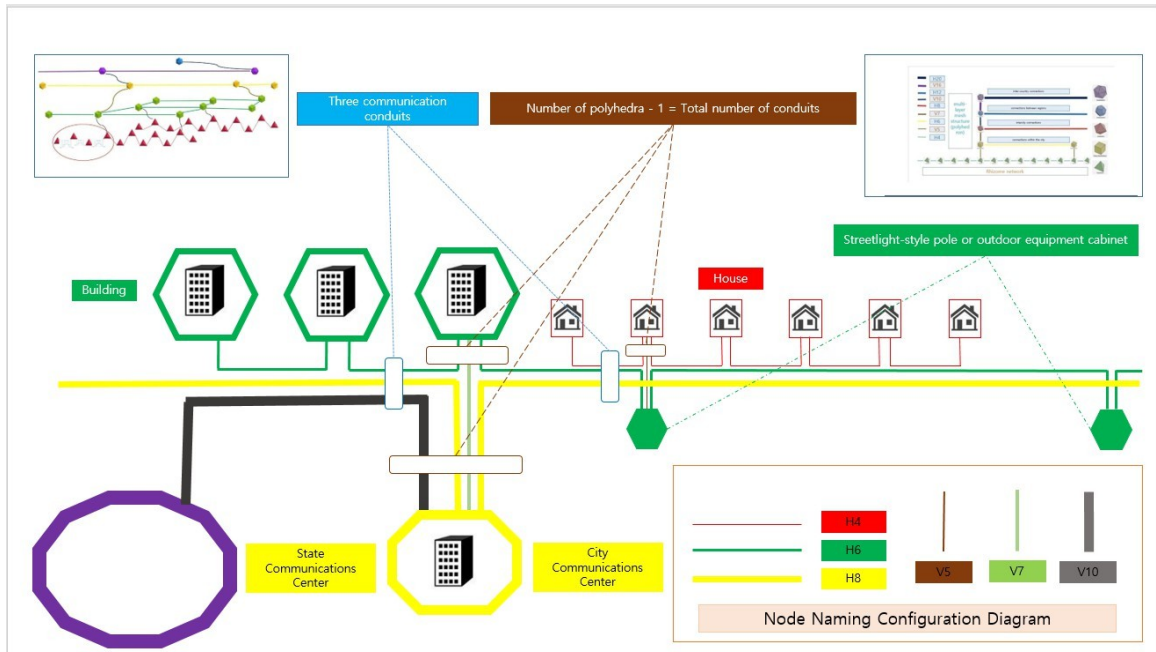

4. Network AI and MAS Structure

4.1 Velsa: The Heart of Network AI

Velsa is the core AI engine of Velsanet, responsible for data collection, analysis, predictive modeling, and self-learning capabilities across the network. It optimizes and manages the network by combining a central control system with a distributed agent system, maximizing efficiency and stability.

Figure: 4.1a Matrix Control Information Extraction System

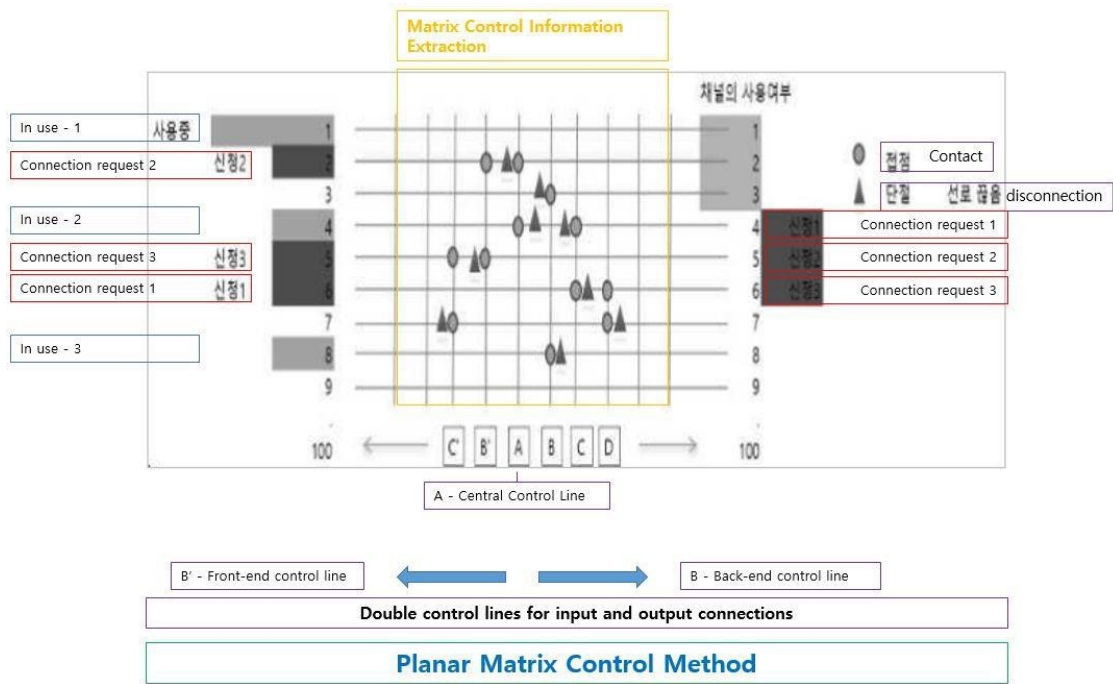

- **A - Central Control Line:** Represents the central control system of the network, managing data flow.
- **B' - Front-end Control Line & Back-end Control Line:** Dual control lines for input and output connections, ensuring the stability of data transmission.
- **Planar Matrix Control Method:** Optimizes data transmission paths through a multi-layer, multi-plane structure.

Figure: 4.1b Multiple Optical Transceivers and Electrical Channels Structure

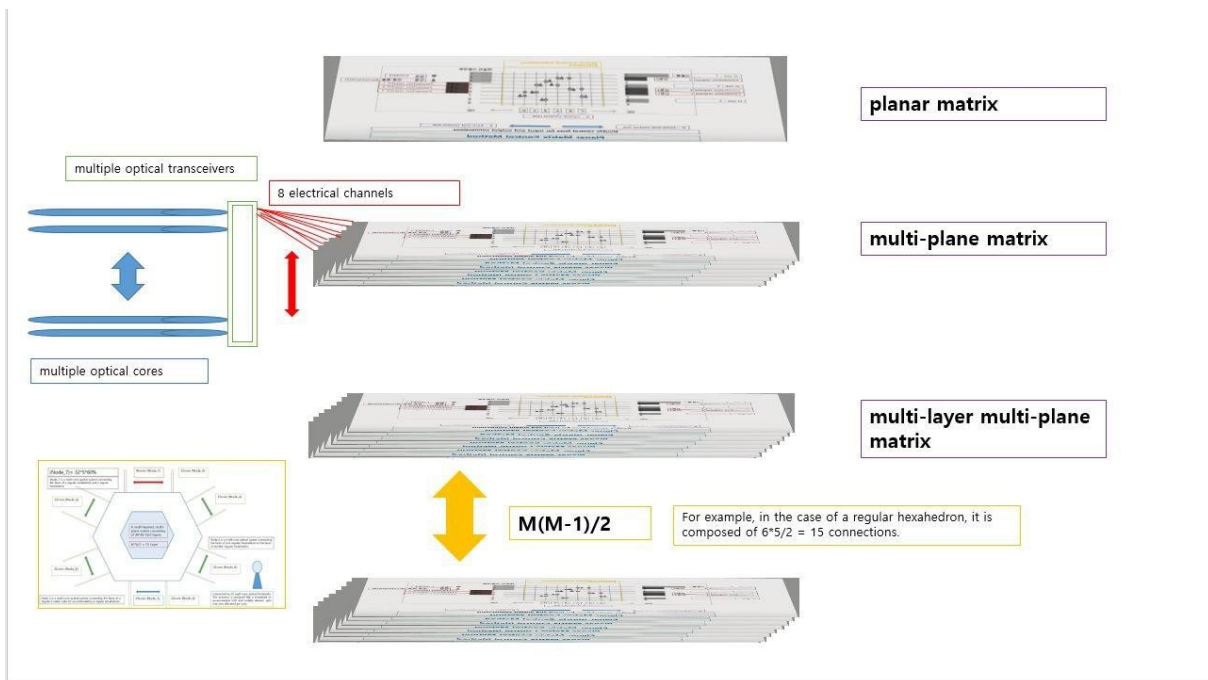

- **Multiple Optical Cores:** The core element of data transmission, enabling parallel data transmission through multiple channels.
- **Multi-layer, Multi-plane Matrix:** For example, in the case of a regular hexahedron, it consists of 6 faces and 15 connections, optimizing data transmission paths.

- **8 Electrical Channels:** Used to maximize data transmission speeds.

- **Central Intelligent Engine**
 - **Data Collection and Analysis:** Collects data across the network and applies big data analysis techniques.
 - **Predictive Modeling:** Anticipates network conditions through machine learning and deep learning for proactive measures.
 - **Self-Learning Capability:** Continuously enhances performance by learning user patterns and network traffic.

- **Network Optimization**
 - **Resource Allocation:** Efficiently distributes network resources to optimize performance.
 - **Fault Response:** Automatically executes recovery procedures and provides alternative paths in case of failures.

4.2 AI Agent Architecture in Velsanet

Velsanet introduces a multi-agent system structured across three intelligent layers: Personal AI (PAI), Agent AI (AAI), and Assistant/System AI (AsAI). These agents operate autonomously while cooperating through a parallel E2E infrastructure.

- **PAI (Personal AI):** Represents the user's personal context, intention, and environment. It manages local decisions and interfaces with the user via multimodal interaction.
- **AAI (Agent AI):** Coordinates clusters of PAI within a region. It performs real-time orchestration and intelligent resource distribution across octahedral nodes.
- **AsAI (Assistant AI):** Oversees AAI cooperation across domains. It supports prediction, policy integration, and multi-domain collaboration among high-level services using dodecahedron and icosahedron structures.

This model replaces centralized intelligence with distributed decision-making embedded directly into the network topology, creating an adaptive, intelligent infrastructure across all layers.

Figure 4.2: Application of Velsa – a parallel E2E AI architecture integrating PAI, AAI, and AsAI.

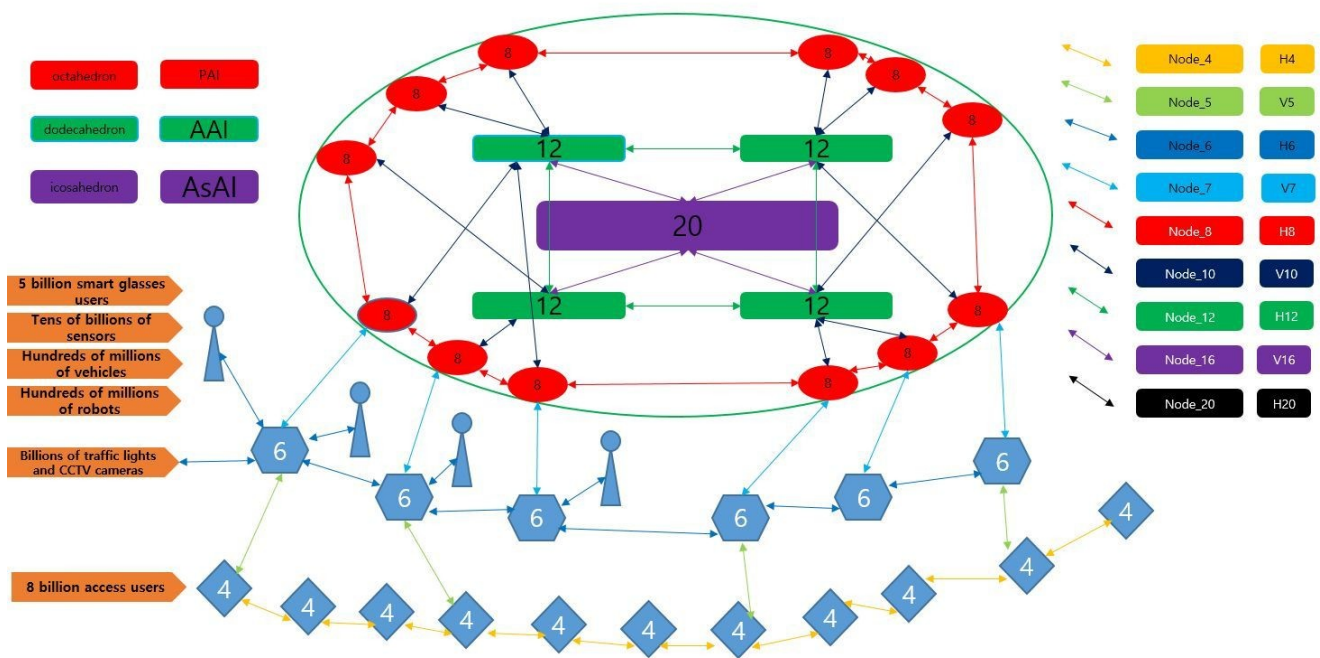

4.3 Layered Deployment and Polyhedral Node Model

The Velsanet architecture organizes network and intelligence layers using geometric node structures. Nodes based on 4, 6, 8, 12, and 20-faced polyhedra correspond to different network functions and AI agents.

- **Node_4 (Tetrahedron) and Node_6 (Hexahedron):** Represent access and RAN connectivity layers.
- **Node_8 (Octahedron):** Hosts Personal AI agents and enables device-level cognitive interaction.
- **Node_12 (Dodecahedron):** Operates Agent AI with dynamic coordination of edge intelligence.
- **Node_20 (Icosahedron):** Supports Assistant AI with global and high-dimensional orchestration.

These polyhedral layers are mapped onto a Q7 hypercube structure, with Schlegel diagram projections representing multidimensional expansion and connectivity.

Figure 4.3: Layered Deployment Model with Schlegel diagram-based polyhedral node structure.

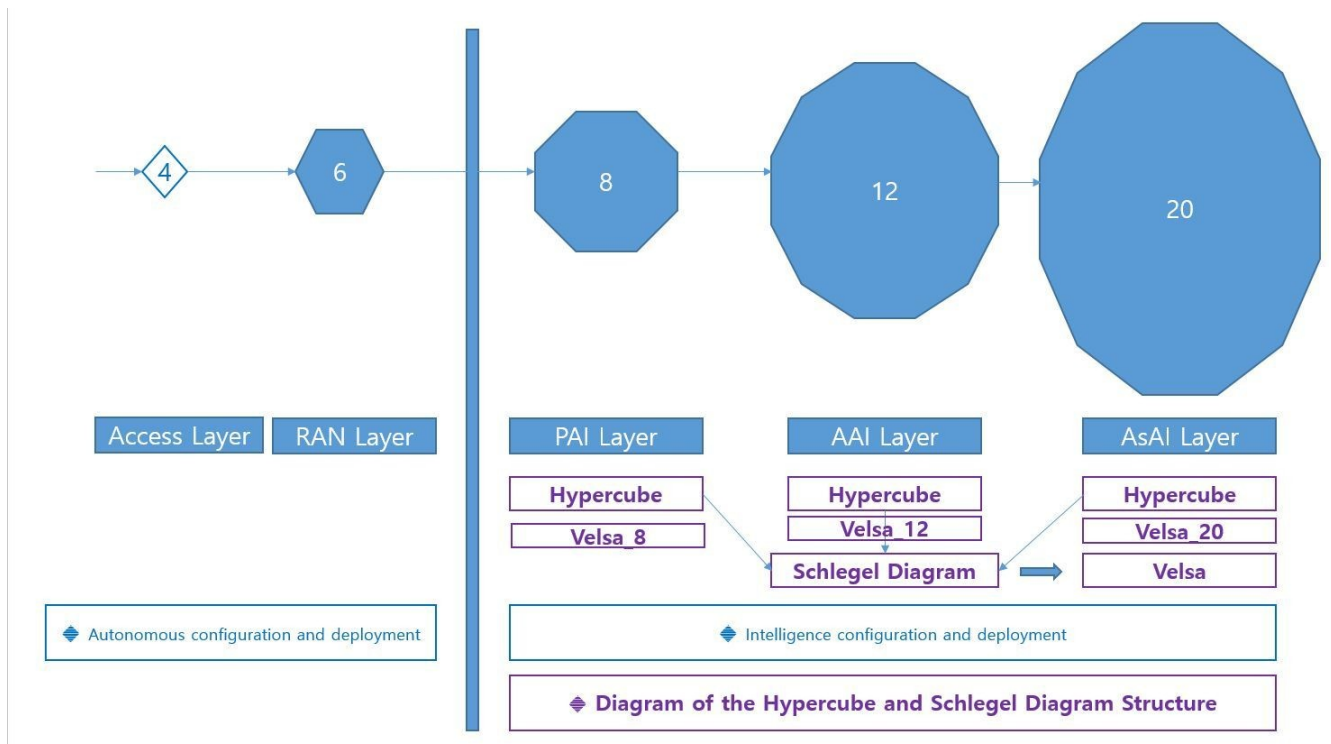

4.4 Intent-Based Flow of Cognitive Signal

Velsanet redefines network cognition as a flow of intent across all signal layers. In this architecture, intention governs every phase—from perception to action—across Access, RAN, and the AI layers (PAI, AAI, AsAI).

- **Data:** Generated by multimodal sensors, collected at Node_4 and Node_6 levels.
- **Information:** Contextualized within PAI nodes (Node_8), where user intent is structured.
- **Knowledge:** Constructed by AAI (Node_12), synthesizing multiple PAI streams to create situational models.
- **Wisdom:** Formed at the AsAI level (Node_20), integrating knowledge across domains for strategic decisions.
- **Execution:** Actionable commands returned to lower layers or external systems.

All of this flows on the backbone of "intent." Intent not only aligns signal paths, but coordinates inter-agent collaboration and autonomous decision-making. This intent structure connects multimodal signal transmission directly to cognition.

Figure 4.4: Intent-centered flow of data, information, knowledge, and wisdom across intelligent layers.

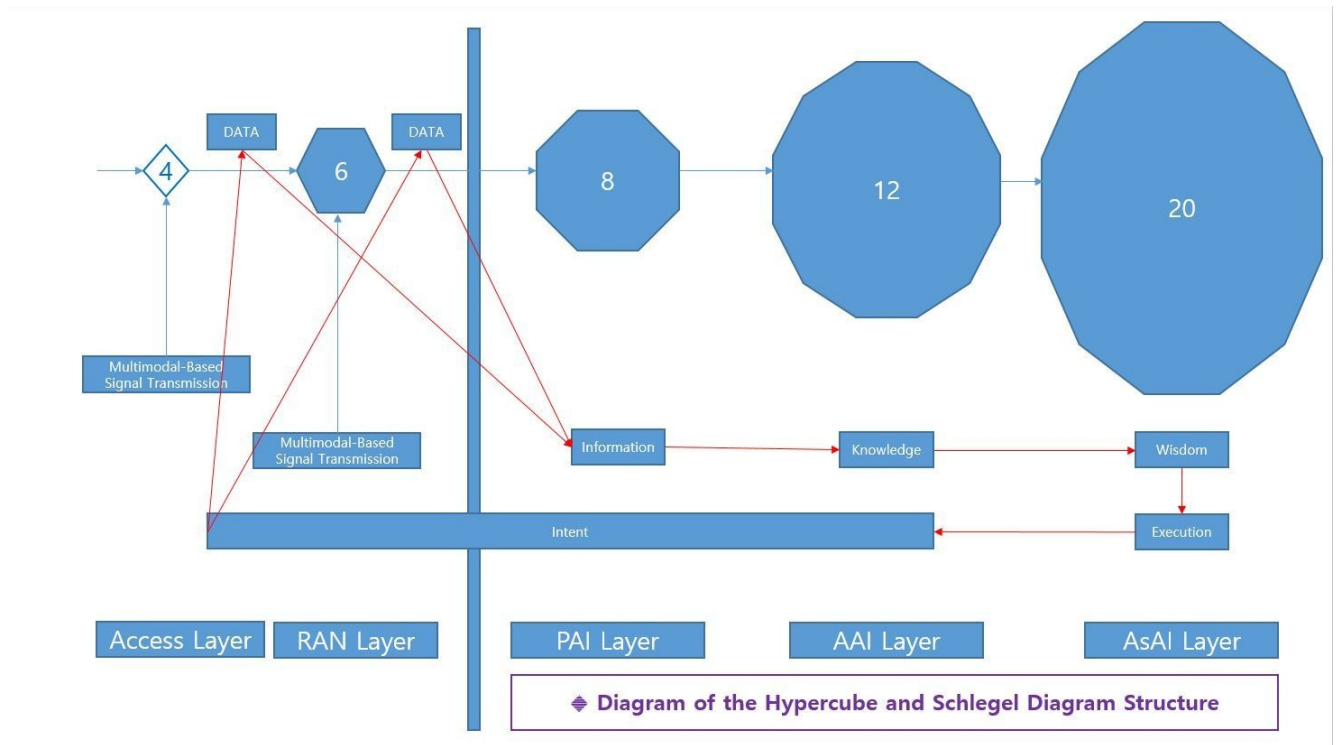

4.5 Intention as the Core of Cognitive Flow

In the Velsanet paradigm, "intention" is not merely a trigger—it is the **substrate** that underlies the entire cognitive process:

1. **Data:** Raw signals from the environment or devices.
2. **Information:** Structured and contextualized data.
3. **Knowledge:** Relational understanding among information units.
4. **Wisdom:** Judgment and insight derived from knowledge.
5. **Execution:** Intelligent actions based on contextual wisdom.

All five stages are driven and unified by **intention**. Intention is the axis around which Velsanet's AI agents—PAI, AAI, and AsAI—sense, infer, coordinate, and act.

- **PAI** captures and expresses personal-level intentions.
- **AAI** aligns and reconciles multiple PAIs to build situational knowledge.
- **AsAI** synthesizes cross-regional intentions into executable policies and strategies.

This intention-driven architecture enables a truly autonomous and adaptive network, where cognition is not imposed from above but emerges from the intelligent alignment of purpose across all layers.

Figure 4.5: Intention-driven structure of data-to-execution across layered AI agents.

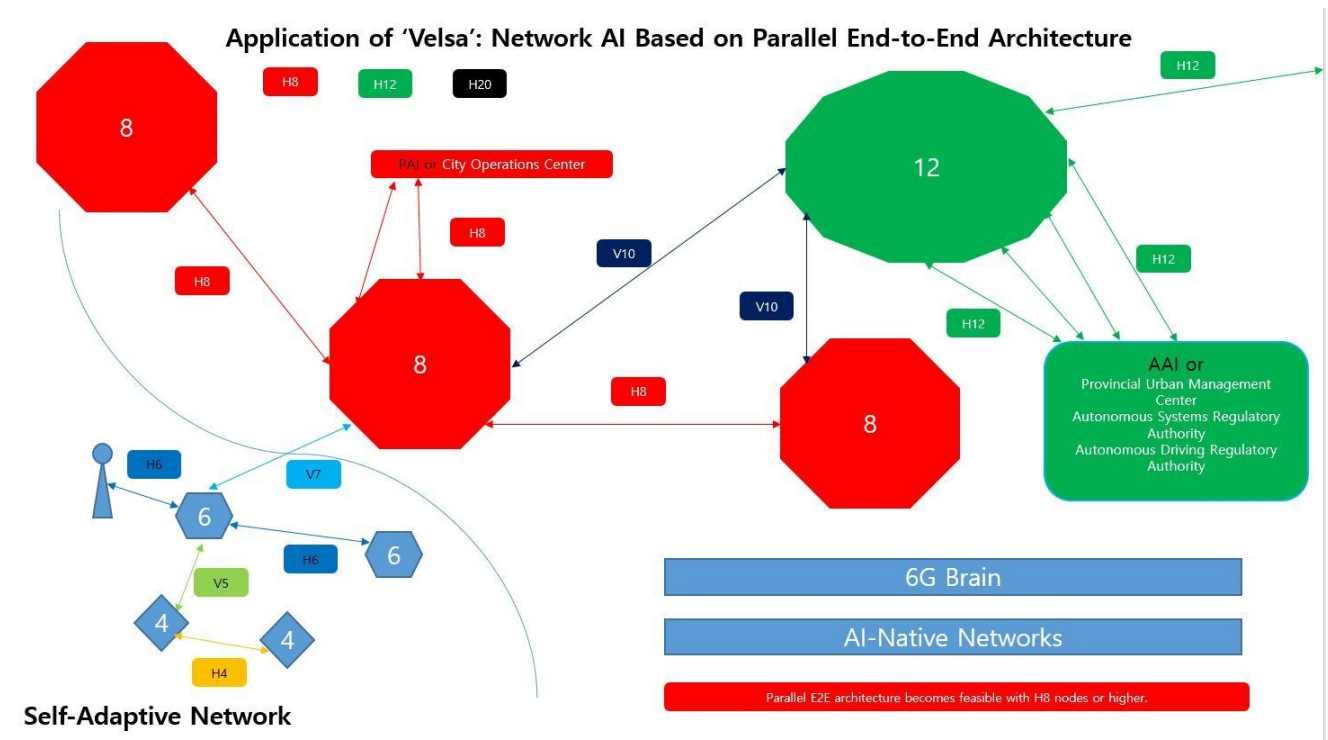

5. Application Fields and Service Integration

5.1 Innovation in Broadcasting and Communication

Velsanet enables next-generation media and communication services:

- **Next-Generation Communication Services:** Supports real-time holographic communication through its multichannel connections. Users can engage in live 3D hologram calls that require simultaneous high-bandwidth data streams.
- **Immersive Experience:** By facilitating 3D holograms and rich media, the network allows users to enjoy a more realistic and immersive communication experience.
- **High Bandwidth Support:** Large volumes of data for holography are handled with ease; the network provides the high bandwidth necessary to transmit holographic or ultra-high-definition content without quality loss.
- **No Integration with the Internet:** Velsanet operates independently from the traditional internet, which enhances security and stability for broadcasting services by isolating them from broader internet traffic and threats.
- **Dedicated Network Environment:** It provides a network environment optimized specifically for broadcasting and communication services (like AR/VR streaming, live holographic events), ensuring these applications run smoothly without competing with general internet traffic.

5.2 Integration of Autonomous Driving and IoT

Velsanet's architecture supports emerging IoT and autonomous vehicle ecosystems:

Autonomous Driving Vehicle Network

- **Real-Time Data Exchange:** Vehicles share traffic conditions, sensor data, and telemetry with each other (V2V) and with infrastructure like traffic lights and road sensors (V2I) in real time, improving situational awareness on the road.
- **Enhanced Safety Systems:** Immediate warnings and coordinated responses (such as automatic braking or rerouting) are enabled to prevent accidents, as vehicles and infrastructure can react collectively to hazards or sudden changes.

IoT Device Management

- **Interoperability among Devices:** Velsanet integrates a vast array of IoT devices (from different manufacturers and with different protocols) under one network. This unified management means devices can seamlessly communicate and be controlled regardless of vendor or standard.
- **Energy Efficiency:** The network supports low-power communication modes, extending the battery life of IoT sensors and devices by using efficient channels and optimizing communication schedules (important for remote or battery-operated IoT devices).

5.3 Industrial Automation and Smart Cities

Velsanet accelerates the development of smart industries and cities:

Implementation of Smart Factories

- **Real-Time Production Management:** The network monitors and controls production lines in real-time, enabling immediate adjustments to manufacturing processes and quick responses to any issues on the factory floor.
- **Predictive Maintenance:** Using sensor data and AI analysis, Velsanet assesses machine conditions continuously to predict when equipment might fail or require maintenance, thus preventing downtime with proactive repairs.

Smart City Infrastructure

- **Traffic Management Systems:** City-wide traffic data is analyzed to optimize traffic light control and routing. The network can adjust signals on the fly and guide autonomous vehicles to alleviate congestion in real time.
- **Energy Management:** Velsanet monitors energy usage across the city (buildings, grid, streetlights, etc.) and manages it efficiently. It can balance load, reduce waste, and respond to peaks by intelligently controlling devices and distributing resources.

6. Technical Challenges and Solutions

6.1 Miniaturization and Efficiency of Equipment

As network devices become more complex, Velsanet addresses size and efficiency challenges:

High-Density Circuit Design

- **3D Integrated Circuits:** Uses 3D chip integration technologies to stack and interconnect circuit components vertically, greatly enhancing space utilization within devices.
- **Application of Nanotechnology:** Incorporates nanoscale components and materials to increase performance while reducing size and power consumption of optical and electronic elements.

Heat Management and Cooling Technology

- **Efficient Heat Dissipation Structure:** Devices are designed with optimized thermal layouts (e.g., heat pipes, graphene layers) to spread and dissipate heat evenly, maintaining stability.
- **Liquid Cooling Systems:** For high-performance optical core transceivers and processors, Velsanet can employ advanced liquid cooling solutions, effectively removing heat and allowing devices to operate at peak performance without overheating.

6.2 Development of Signal-Based Communication Protocols

To fully utilize multichannel capabilities, Velsanet explores advanced communication protocols:

Signal Processing Algorithms

- **High-Speed Modulation Techniques:** Research is ongoing into new modulation methods (beyond traditional QAM, OFDM, etc.) that can pack more data into optical/electrical signals, thereby increasing transmission speeds on each channel.
- **Error Detection and Correction:** Robust algorithms are employed to detect and correct errors in transmission in real time, ensuring data integrity even over high-speed or noisy channels.

Protocol Development

- **Acceptance of Digital Signals:** Velsanet's protocols are designed to accept and integrate all forms of digital signals, whether from legacy systems or novel devices, providing universal compatibility for any digital data.
- **Channel Mapping Technology:** The network implements intelligent channel mapping which efficiently assigns and translates data streams to available channels, optimizing throughput and minimizing interference by dynamically re-routing signals as needed.

6.3 Security and Privacy Protection

Security is a core focus in Velsanet's independent network design:

Encryption Technology

- **Quantum Encryption:** Velsanet looks toward future-proof security by considering quantum encryption methods. These techniques use principles of quantum mechanics to secure communications against even quantum-computer attacks.
- **End-to-End Encryption:** All data transmitted across Velsanet can be encrypted from the source to the destination, ensuring that even if intercepted, the data remains confidential and unaltered.

Access Control and Authentication

- **Multi-Factor Authentication:** The network supports strong authentication methods, combining something users know (passwords), have (devices or tokens), and are (biometrics) to verify identities.
- **Permission Management System:** Fine-grained access control policies manage what users and devices can do in the network, ensuring each entity only accesses resources it's permitted to.

Privacy Protection Policy

- **Data Minimization Principle:** Velsanet adheres to collecting and storing only what data is absolutely necessary, reducing risk by not hoarding excess personal or sensitive information.
- **Providing Transparency:** Users are clearly informed about how their data is used and for what purposes. This openness builds trust and allows users to understand and control their data footprint.

7. Collective Intelligence and Organic Growth in the Velsanet Network

7.1 Concept of Collective Intelligence

The collective intelligence of Velsanet is a **distributed cognitive structure** formed through the **exchange of intent**.

Each node operates as an independent unit of intelligence, generating shared understanding and direction through feedback.

Intelligence adjusts autonomously without central control, allowing the entire network to function as a unified cognitive system.

7.2 Cognitive Circulation Structure

Velsanet expands the **DIKWEI structure** (*Data → Information → Knowledge → Wisdom → Execution → Intent*) into a **collective cognitive cycle**.

Each node collects data, shares information, and reflects execution results at the level of intent.

This cycle enables continuous learning and renewal across the entire network, operating as a **self-reconfiguring mechanism of intelligence**.

7.3 Structure of Organic Growth

The growth of Velsanet is based on **self-organization** and **adaptive evolution**. The network restructures itself according to environmental and intentional changes, sustaining morphological expansion through its parallel E2E architecture and polyhedral nodes. This structure functions as a **self-evolving system** in which intelligence develops autonomously.

7.4 Ecological Intelligence

Velsanet extends into an **intelligent ecology** where humans, AIs, cities, and environments interact as cognitive entities. Each element acts independently yet maintains balance through the exchange of intent and signals. This structure is founded on **co-evolution rather than control**, allowing the network to operate as an integrated, living cognitive organism.

8. AI-Native Network Structure and Intelligent Connectivity

8.1 Introduction

Velsanet is not a network with intelligence added to it. It is a network **in which intelligence exists as structure**. The system does not merely transmit data — it **interprets intent, understands context, and evolves through connection**.

8.2 Structural Intelligence of the Network

Each node functions as both a communication point and a cognitive unit. Learning and reasoning occur everywhere in the network.

- **Node 6:** foundation for spatial and temporal awareness
- **Node 8:** personalized intelligence linking intent and environment
- **Node 12:** relational and regional coordination
- **Node 20:** collective reasoning and global cognition

Intelligence is spatially distributed, and intent flows organically through the network.

8.3 Parallel E2E Connectivity

Connections are formed by intent and sustained through understanding. Each link interprets its own interaction and adjusts dynamically within the flow. Information exchange occurs as **semantic interaction**, not as packet transmission. The network evolves into a system that **thinks through its own connections**.

8.4 Organic Evolution and Collective Learning

New nodes and intelligences merge seamlessly into the shared continuum.

Local insights expand into global comprehension.

Intent becomes memory; memory transforms into new awareness.

Through this cycle, the network **learns, remembers, and reshapes itself.**

8.5 Meaning of AI-Native Design

In Velsanet, the physical and cognitive layers are one.

Form equals function; structure equals intelligence.

Every signal carries purpose, and every connection reflects understanding.

Intelligence is not hosted on the network —

the network itself is intelligence.

9. Conclusion

Velsanet is an innovative solution designed to overcome the limitations of existing networks and meet future communication demands. As a multi-optical-core, end-to-end multichannel intelligent network, it supports direct and efficient communication between users and services, for example providing the multichannel connections needed for holographic communication. Its channel structure connects multiple channels without service-type distinctions, accepting any form of signal capable of digital transmission. Velsanet also accommodates femtocell-based mobile networks, aligning wireless multichannels with wired optical core multichannels - enabling the world to function as a single global telecom operator in practice.

By combining the Rhizome network of users with a multilayer mesh network of service providers, Velsanet forms a unified ecosystem of users and services. The polyhedron-based 3D distributed network structure, intelligent network management through MAS, and close collaboration between Central AI and Auxiliary AIs all maximize network efficiency and stability. Additionally, through strategic partnerships with global telecom companies and active collaboration with academia, we aim to pursue technology disclosure and transparency, realizing the democratization of technology.

Through these efforts, Velsanet will open the era of personal AI and lead innovation across various industrial fields - transforming not only how we communicate, but also how we live and interact in an increasingly connected world.

10. References

1. **Research on Network Structures and Rhizome Concepts**
Deleuze, G., & Guattari, F. (1980). A Thousand Plateaus.

University of Minnesota Press.

2. **Theory and Application of Multi-Agent Systems**
Wooldridge, M. (2009). An Introduction to MultiAgent Systems. Wiley.
3. **AI and Network Integration Strategies**
Russell, S., & Norvig, P. (2020). Artificial Intelligence: A Modern Approach. Pearson.
4. **Development of Next-Generation Communication Protocols**
Peterson, L., & Davie, B. (2011). Computer Networks: A Systems Approach. Morgan Kaufmann.
5. **Technologies for Security and Privacy Protection**
Schneier, B. (2015). Data and Goliath: The Hidden Battles to Collect Your Data and Control Your World. W.W. Norton & Company.
6. **From Artificial Intelligence to Active Inference**
Maier, M. (2023). The Key to True AI and the 6G World Brain.
7. **Internet of Intelligence**
Li, R., Zhao, Z., Xu, X., Ni, F., & Zhang, H. (2020). The Collective Advantage for Advancing Communications and Intelligence.

No. 02

Velsanet Wired–Wireless Convergence White Paper

02

Velsanet Wired–Wireless Convergence White Paper

1. Purpose of This Document

This white paper defines how wireless access integrates with Velsanet’s optical Layer-1, focusing exclusively on:

- **mapping wireless signals into optical cores,**
- **individual E2E creation,**
- **parallel E2E expansion,**
- **mobility and handover,**
- **the role of the V-MCU (Velsanet Mobility Convergence Unit).**

This document **does not** address Velsanet AI Layers (PAI/AAI/AsAI) or inter-city/core-network connectivity, which belong to separate white papers.

2. Scope of Wired–Wireless Convergence

Wireless access in Velsanet is **not a network**, but an **entry point** into the optical domain.

- The wireless signal is received at the radio unit.
- The signal is immediately mapped into an **optical core**.
- From that moment onward, the communication is handled entirely by Velsanet’s Layer-1 optical architecture.

Therefore:

Wireless simply determines how the user reaches the optical core; all network behavior begins after optical mapping.

This document only describes that mapping.

3. Optical Mapping Structure (8-Channel – 1 Optical Core)

Each wireless device is mapped to:

- **one optical core (individual E2E)**
- composed of **8 internal optical channels**.

Key principles:

1. A device = one optical core for individual E2E
2. Channels are not separate cores; they are internal lanes
3. The 1st channel is always reserved for
 - o device monitoring
 - o topology awareness
 - o E2E creation signaling (TCC)

This mapping is universal for all Access Layer nodes (Layer-4/6/8).

Note – Wireless-to-Optical Channel Mapping

The detailed rules for mapping the wireless 8-channel link to individual optical cores will be defined after the establishment of the Velsanet Research Lab.

This white paper focuses on the **structural architecture and conceptual framework**,

while the precise convergence mechanics will be finalized through real hardware testing and joint research once the Lab is operational.

4. Role of the V-MCU (Velsanet Mobility Convergence Unit)

The V-MCU is **not part of Velsanet equipment**.

It is an **external coordination module** for the wireless domain.

V-MCU is responsible **only for three things**:

4.1 Individual E2E Management

- Keep track of which device uses which optical core
- Create and release individual E2E paths
- Maintain mapping tables for mobility

4.2 Parallel E2E Creation

Parallel E2E is simply **multiple individual E2Es assigned to the same device.**

Process:

1. Device requests parallel E2E
2. V-MCU determines next available optical core
3. V-MCU issues command to Velsanet equipment:
 “Activate next optical core and connect it to this device.”
4. Velsanet Layer-1 creates the physical path

Parallel E2E = repetition of individual E2E.

4.3 Mobility / Handover

Mobility is achieved through **overlapped E2E:**

1. Existing E2E remains valid
2. A new E2E is pre-created in the target cell
3. When stable, the old E2E is released

No packet loss.

No PHY/MAC handover complexity.

No re-routing.

V-MCU controls the sequence; Velsanet equipment only executes core activation.

5. What V-MCU Does NOT Do (Critical Clarification)

To avoid conceptual confusion:

V-MCU does not manage inter-city or inter-region routing

Those are handled by:

- Layer-12 (AAI nodes)
- Layer-20 (AsAI nodes)
- Polyhedral E2E structure

These layers belong to the **Velsanet Network AI** and **Matrix Architecture** white papers.

V-MCU does not control optical switching matrices

Layer-1 autonomous optical intelligence handles that.

V-MCU does not handle wired-wireless synchronization

That belongs to the radio unit and optical Layer-1 mapping.

V-MCU does not optimize high-level traffic

Its only job is device-level E2Es.

6. Resource Allocation Principle (Access Layer Only)

To simplify mobility:

All Access Layer nodes (Layer-4/6/8) must use identical optical core resources.

Reason:

- Prevent mismatch during handover
- Simplify parallel E2E extension
- Eliminate unnecessary allocation logic in V-MCU
- Maintain deterministic behavior

V-MCU manages **only Access Layer cores**, not the global core pool.

7. Summary of the Convergence Model

Velsanet wired-wireless convergence is defined by:

- **Wireless provides access – Optical Layer-1 becomes the network**
- **Individual E2E = 1 optical core**
- **Parallel E2E = multiple individual E2Es**
- **V-MCU = control of E2E, parallelization, mobility**
- **Layer-12/20 = global routing – entirely separate**
- **Handover = overlapped E2E**
- **Access Layer = standardized optical core resources**

This structure isolates wireless complexities and guarantees deterministic behavior in the optical layer.

Conceptual Only — Implementation Deferred

The wireless-to-optical channel mapping mechanism described in this document represents a conceptual architecture. Its detailed physical implementation, including mapping rules, modulation alignment, and hardware integration, will be finalized after the establishment of the Velsanet Research Lab.

No. 03

Velsanet Multi-Optical-Core Transceiver (MOCT) White Paper

03

Velsanet Multi-Optical-Core Transceiver Architecture White Paper (v1.0)

A Fixed, AI-Operated, Multi-Layer Photonic Substrate for Parallel E2E Connectivity

1. Introduction

Velsanet abandons packet switching and routing entirely. It forms deterministic, parallel end-to-end optical paths through a unified matrix-transceiver physical substrate. Connectivity is passive, structural, and physically authenticated.

2. Architecture Overview

Velsanet defines a structural rule: the multi-plane matrix and multi-optical-core transceiver (MOCT) operate as a single merged substrate. No switching ASICs or forwarding logic exist. Optical paths are formed purely through physical parallel cores.

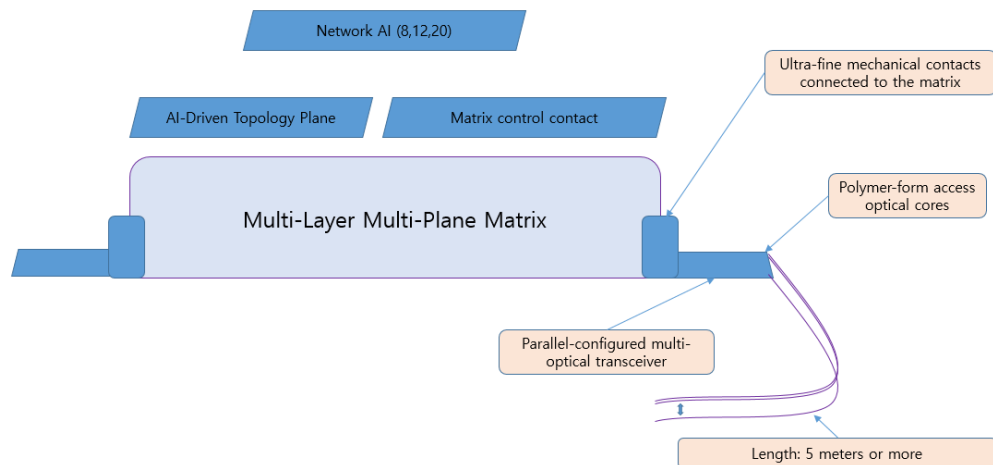

Network AI → Topology Plane → Matrix → Parallel Transceiver → Fiber (5m+)

3. Component Flow of the Multi-Optical-Core Transceiver

The MOCT is a fixed, non-pluggable module integrated directly with the matrix. It includes:

- MEMS-based ultra-fine contacts
- Parallel optical cores (tens to hundreds)
- 8 physical channels per core (Ch1 = sensing/control)
- Pre-attached fibers of 5 meters or more.

This creates a continuous optical chain without connectors.



1. Ultra-fine mechanical contacts connected to the matrix — providing physical bonding and alignment.
2. Parallel-configured multi-optical transceiver — a fixed, non-pluggable photonic module.
3. Polymer-form access optical cores — flexible, durable, low-loss transition layer.
4. Pre-attached optical fibers (5 meters or more) — forming a direct optical path with zero connectors.

4. Key Innovations

4.1 Fixed, Non-Pluggable Optical Module

The MOCT is permanently attached to the matrix and cannot be removed or swapped like QSFP/SFP modules.

4.2 Pre-Attached Long Optical Fibers (5m+)

Fibers are fused at the factory and shipped as inseparable extensions of the transceiver.

4.3 Ultra-Fine Mechanical Contacts

These contacts replace patch panels and provide stable micro-scale alignment.

4.4 Parallel Multi-Core Photonics

Supports tens to hundreds of simultaneous optical cores enabling true parallel E2E communication.

5. Technical Motivation and Problem Definition

Next-generation AI-native networks require an optical infrastructure that supports deterministic parallelism, physical-layer authentication, long-term stability, and fully passive operation. However, existing optical networking architectures—based on pluggable modules, connector-dependent fiber interfaces, and electrical switching devices—cannot meet these requirements.

This section defines the fundamental limitations of existing systems and the motivation behind the Velsanet Multi-Optical-Core Transceiver (MOCT) architecture.

5.1 Limitations of Connector-Based Optical Systems

Traditional optical networks depend on LC/SC/MPO connectors and pluggable modules (SFP/QSFP). These introduce unavoidable reliability issues:

- mechanical wear from repeated insertion cycles
- contamination and microscopic debris on connector surfaces
- oxidation of metallic interfaces
- insertion-loss variation over time
- thermal expansion causing alignment drift

As a result, **optical stability is never guaranteed**, and continuous technician maintenance becomes mandatory.

This makes connector-centric systems fundamentally unsuitable for large-scale, autonomous, AI-driven operations.

5.2 Switching Bottlenecks in Electrical-Optical Architectures

Current optical systems require:

- electrical switching silicon
- routing logic
- protocol-layer packet handling
- buffering and signal regeneration

These elements introduce:

- additional latency
- error points
- heat generation and power consumption
- architectural fragility from stateful control logic

Because of this dependency, **true physical-layer parallel E2E** cannot be achieved. The architecture remains inherently serial and electrical in nature.

5.3 Fragility of Single-Path Optical Dependencies

Most optical transceivers operate on:

- one or two cores
- limited redundancy
- linear optical routing

A single fiber micro-bend, splice failure, or core defect can **collapse the entire link**.

Large-scale AI-native networks, however, require:

- multi-path resilience
- distributed physical redundancy
- core-level fault isolation
- structural error tolerance

Current architectures were never designed for this.

5.4 Absence of Physical-Layer Authentication

Modern networks authenticate at upper layers (TLS, IPSec, QUIC, etc.). However, **optical paths themselves have no self-verifying mechanism.**

This leads to fundamental vulnerabilities:

- physical MITM possibility
- spoofed path negotiation
- inability to validate the authenticity of optical endpoints
- no verification of physical-hop continuity

AI-native E2E security must begin at the *physical layer*, but existing systems simply do not support this.

5.5 Structural Problem Summary

The limitations above define a clear problem:

1. **Optical connectors cannot secure long-term physical reliability.**
2. **Electrical switching blocks true parallel optical connectivity.**
3. **Single-path architectures lack fault tolerance.**
4. **Physical paths cannot authenticate themselves.**

These limitations are not solvable through software, better firmware, or incremental hardware design.

To overcome them, a fundamentally new physical architecture is required—one that:

- eliminates connectors
- removes electrical switching
- integrates the matrix and transceiver into a single deterministic structure
- uses semiconductor lithography for alignment
- employs MEMS for static precision bonding

- supports parallel multi-core optical paths
- enables physical-layer E2E verification

This leads directly to the development of the **Velsanet Multi-Optical-Core Transceiver (MOCT)**.

6. Mechanical & Optical Integration Design

6.1 Ultra-Fine Mechanical Contact Interface

High-density micro contacts ensure vibration-resistant positioning and long-term optical stability.

6.2 Matrix Bonding and Structural Integrity

The MOCT forms a composite mechanical-photonic unit with the matrix, removing connector-related instability and creating a physically integrated optical substrate.

7. Optical Core Density & Parallelism Model

Core density roadmap:

- Phase 1: 100 cores
- Phase 2: 200–500 cores
- Phase 3: 1000+ cores

Parallelism enables independent optical circuits, dynamic grouping, and hyper-dimensional topology expansion.

8. Layered Matrix-Transceiver Physical Structure

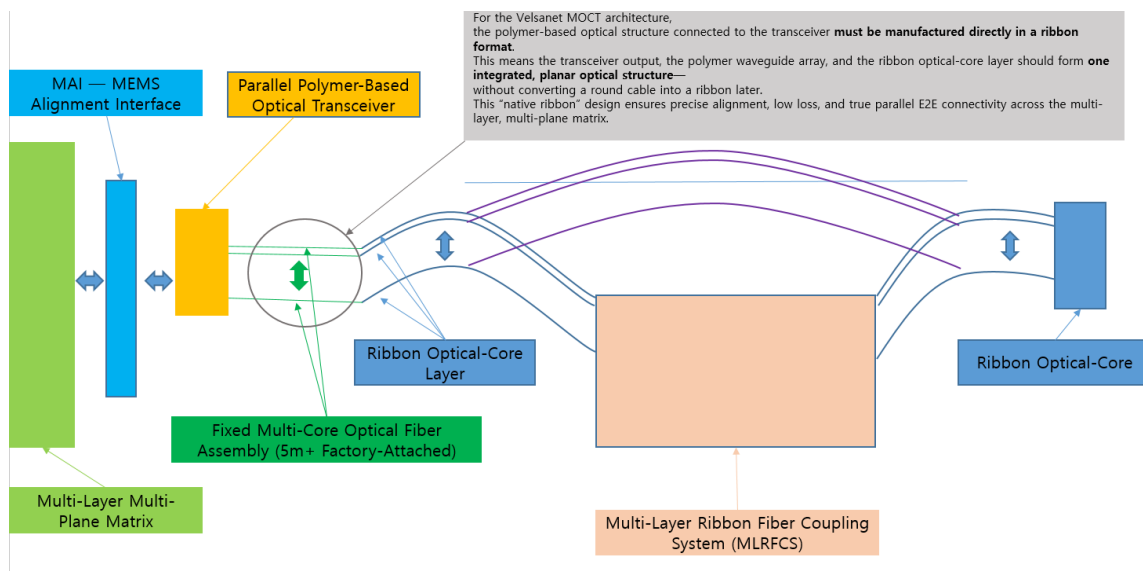

Figure 8. Polymer-Based Ribbon Optical-Core Integration Architecture

This figure illustrates how the MOCT transceiver, the polymer-based optical core layer, and the multi-layer multi-plane matrix form a unified photonic structure.

The **MEMS Alignment Interface (MAI)** aligns the transceiver's parallel polymer waveguide array with the fixed multi-core optical fiber assembly, which is manufactured directly in a ribbon format.

Because the polymer waveguide, transceiver output, and ribbon optical cores form a single planar integrated structure, no round-to-ribbon conversion is required.

The **Ribbon Optical-Core Layer** then provides a flattened, layer-by-layer parallel optical pathway that couples directly into the **Multi-Layer Ribbon Fiber Coupling System (MLRFCS)**.

This system maintains deterministic mapping toward the **Multi-Layer Multi-Plane Matrix**,

ensuring low loss, precise mechanical-optical alignment, and true parallel E2E photonic connectivity within the Velsanet MOCT architecture.

8.1 Polymer-form Optical Core Layer

The first physical layer of the matrix–transceiver integrated structure is the *polymer-form optical core layer*.

Each optical core is fabricated using high-precision polymer photonic structures designed to support stable, low-loss optical propagation.

Every optical core is internally divided into **eight fixed physical channels**, with the following mandatory roles:

- **Channel 1** – Sensing & control (device authentication, physical alignment verification, bootstrap)
- **Channels 2–8** – Parallel optical data transmission

This layer establishes Velsanet's fundamental parallelism.

Because all channels are fixed and non-switchable, the optical paths remain deterministic, passive, and immune to logical interference.

8.2 Ultra-fine Mechanical Contact Layer

The second layer consists of *ultra-fine mechanical contacts* that provide micron-level alignment between each optical core and the semiconductor photonic matrix.

These contacts:

- are static (no moving or switching elements)

- maintain permanent physical pressure and alignment
- ensure minimal optical coupling loss
- provide vibration-resistant structural stability
- require no operational power

This mechanical interface is essential to preserving the integrity of passive optical connectivity and enabling large-scale parallel E2E communication.

8.3 Semiconductor & MEMS Alignment Layer

The third layer is the *semiconductor-based photonic matrix* combined with MEMS alignment structures.

The matrix is implemented using silicon photonics, allowing:

- lithographic precision of alignment patterns
- high-density optical contact arrays
- manufacturability at scale

Static MEMS alignment elements ensure the exact physical positioning of each core-to-matrix junction.

They do not perform switching; instead, they guarantee permanently accurate optical pathways.

Because the density of MEMS-semiconductor contacts scales similarly to semiconductor I/O pads, the architecture supports **hundreds of optical cores** without exceeding manufacturing limits.

Minor defects are naturally handled through the auto-sensing process, which excludes unusable cores.

8.4 Pre-attached Fiber Layer

The fourth layer consists of *pre-attached optical fibers*, permanently fused at the factory to eliminate connector losses.

Key properties:

- length: **5 meters or more**
- permanently bonded (non-detachable)
- optimized for low-loss, multi-plane distribution
- stable under environmental and mechanical stress

By integrating the fiber as part of the transceiver assembly, Velsanet ensures a continuous optical substrate from the matrix interface to the extended physical layer.

9. Reliability & Lifecycle Model of the Matrix-Transceiver Integrated System

The reliability of the Velsanet Multi-Optical-Core Transceiver (MOCT) architecture derives directly from its physical design principles:

fixed optics, non-switchable pathways, semiconductor-level alignment, and permanently fused fibers.

This section outlines the structural, operational, and lifecycle reliability characteristics of the MOCT within the Velsanet ecosystem.

9.1 Structural Reliability from Fixed Optical Architecture

MOCT eliminates the dominant failure modes of traditional optical systems:

- no pluggable modules
- no mechanical latches
- no user-installed fiber connectors
- no connector oxidation or contamination

Each optical core is permanently aligned using static mechanical pressure and MEMS-assisted alignment structures.

Because the cores are physically fixed and non-switchable, *there is no moving part to degrade, loosen, or drift over time.*

Result:

A long-term stable optical path with near-zero alignment drift and no operator-side maintenance.

9.2 Semiconductor & MEMS Alignment Stability

The semiconductor-MEMS layer provides a lithographically defined alignment pattern, ensuring:

- micron-level positional accuracy
- no mechanical fatigue (no actuated MEMS)
- no dependency on springs, latches, or connectors

- temperature-invariant physical anchoring

Silicon photonics structures naturally maintain stable refractive and mechanical properties over decades, as long as structural stress remains constant.

This gives MOCT a reliability profile similar to semiconductor packaging rather than telecom connectors.

9.3 Multi-Core Fault Tolerance Through Parallelism

MOCT does not rely on a single optical core or path.

Its **multi-core, multi-channel parallelism** inherently provides fault tolerance:

- individual defective cores are automatically excluded during initial link sensing
- mapping is performed via Channel 1 of each core
- Channels 2–8 remain available for active transport
- parallel redundancy reduces the impact of fiber micro-bending or partial defects

As a result, even with partial degradation of the array, the system continues to operate normally.

Fault tolerance is built into the physical substrate itself, not added through logical redundancy.

9.4 Permanently Fused Fiber Reliability

By integrating 5m+ fibers directly into the transceiver at manufacturing time:

- no connector mating cycles
- zero need for polishing, cleaning, or re-seating
- no insertion-loss variation
- extremely low long-term failure rate
- no field-installation error potential

The fiber becomes part of the device's permanent mechanical assembly.

This guarantees a consistent optical performance profile throughout its lifecycle.

9.5 Expected Lifecycle and MTBF Profile

Based on the elimination of traditional connector-based failure modes, MOCT exhibits:

- expected MTBF improvements of **10× or more** compared to pluggable optics
- minimal field maintenance requirements
- no operational degradation due to connector wear
- extremely low long-term optical drift
- predictable performance for multi-decade operation

In large-scale Velsanet deployments, this results in:

- significant reduction in OPEX
- simplified infrastructure management
- near-zero unplanned downtime
- improved service reliability for all access-node and AI-node connections

9.6 Summary

The MOCT's reliability is not an add-on feature;
it is a direct and unavoidable consequence of its physical architecture.

By combining:

- fixed optical pathways
- semiconductor-grade alignment
- MEMS-enhanced stability
- parallel multi-core transport
- and permanently fused fiber outputs

Velsanet establishes a new category of optical infrastructure—
 one that behaves more like a *solid-state optical medium* than a traditional networking component.

This fundamental stability enables the ultra-large-scale, AI-driven, parallel E2E connectivity required for the next generation of intelligent networks.

10. Comparison with Conventional Optical Systems

Feature	QSFP/SFP	Velsanet MOCT
Replaceable Module	Yes	No (Fixed)
Fiber Connection	External connector	Pre-attached permanent fiber
Optical Core Count	4–8	100–1000+

Connector Loss	Yes	None
Stability	Low	High
AI Physical Control	Impossible	Native
Topology Reconfiguration	No	Yes
Parallelism	Limited	Massive

11. Conclusion

The MOCT architecture defines the first AI-operable physical photonic substrate. By integrating fixed optics, pre-attached fibers, ultra-fine mechanical contacts, and multi-core photonics, the system enables parallel E2E connections and multidimensional topology formation beyond the capabilities of traditional telecom systems.

No. 04

Velsanet Matrix Architecture White Paper

04

Velsanet Matrix Architecture White Paper

1. Introduction

This section explains the foundational shift from packet-based networking to AI-native connectivity, where networks must support multi-agent, real-time multimodal processing. Velsanet introduces a matrix-based, semiconductor-inspired architecture enabling global-scale multi-layer interconnects.

Key components include:

- Single-layer matrix switching
- Eight-layer optical channel stacking
- Face-level matrix construction
- Combinatorial face-to-face connectivity
- Polyhedral 3D routing topologies
- Hyperparallel multi-channel E2E pathways

This document focuses exclusively on the physical, structural, and mathematical architecture of Velsanet's multi-layer matrix and polyhedral switching fabric.

The operational behavior of PAI, AAI, and AsAI — including intent processing, routing decisions, and network-level control — is explicitly outside the scope of this paper and is addressed in the separate Velsanet Network AI White Paper.

2. Semiconductor Origins of the Matrix Architecture

Modern semiconductors rely on crossbar switches, multi-metal-layer routing, parallel interconnects, and Network-on-Chip structures. Velsanet extends these principles globally, treating each node as a semiconductor tile and each polyhedron as a 3D routing entity.

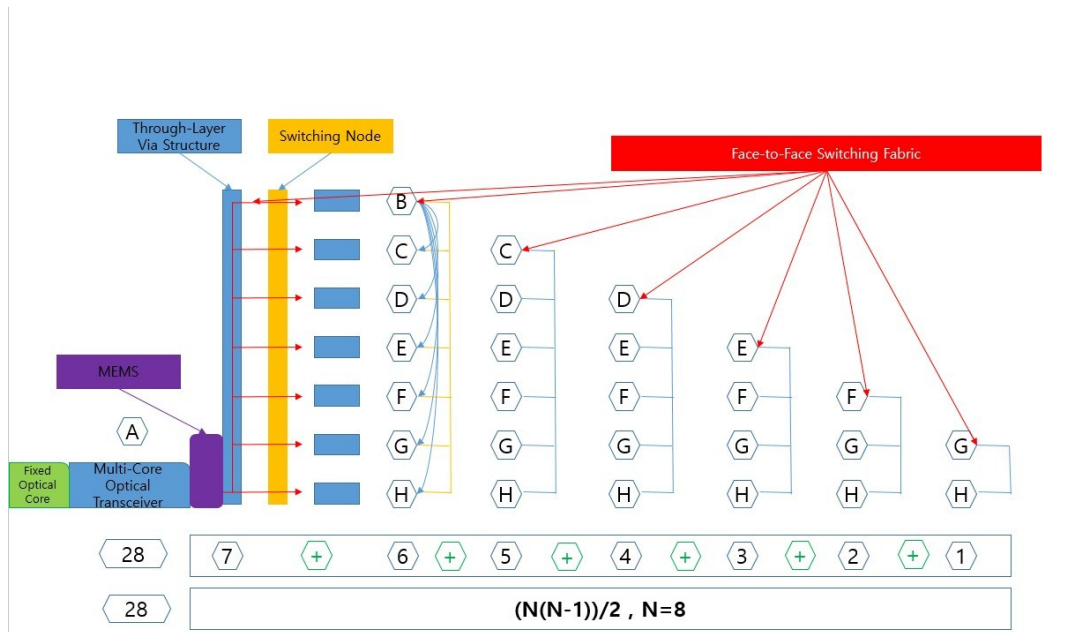

Figure 2. Semiconductor-Inspired Matrix Switching Architecture (N = 8 Case)

Use this description directly under the figure:

This diagram illustrates how a multi-core optical transceiver connects to a fixed optical core and routes signals through a through-layer via structure toward the switching node. Each vertical finger port serves as an ingress/egress access point to the Single-Layer Matrix (SLM), allowing directional selection as defined by the switching control logic.

The switching node then maps each input to one of eight output faces (B–H), producing the complete set of $N(N-1)/2 = 28$ possible face-to-face switching paths.

These paths represent the fundamental connectivity required for constructing a polyhedral, multi-plane switching fabric, where each face can independently connect to all other faces.

This architecture demonstrates how semiconductor-style matrix switching—via structures, directional control, and cross-point activation—can be expanded directly into a networkscale matrix, forming the structural basis for Velsanet’s E2E and parallel E2E optical pathways.

Velsanet employs MEMS-based micro-fabricated alignment fixtures for fiber-to-chip coupling.

These structures ensure that multi-core fibers are positioned accurately over the matrix input interfaces.

No MEMS switching, actuation, or beam steering is used within the matrix itself.

3. Single-Layer Matrix (SLM)

SLM is the atomic switching unit managing exactly one optical channel. It uses directional control and a single activated cross-point to generate deterministic E2E flows.

Mathematical definition:

SLM = 1 channel – 1 E2E path

3.1.1 Patent Foundation – Claim 1 (Ready for Insertion)

This subsection is intentionally prepared to allow direct insertion of Claim 1 from KR 102023-0056157.

Place the full text of Claim 1 here, followed by its interpretation and mapping to the SLM switching behavior.

▼ Suggested Structure:

Claim 1

A method of connecting ports through a matrix, the method comprising:

1. **receiving connection information of a subscriber port from a subscriber;**
2. **acquiring usage information of a transmission port;**
3. **selecting a front-side or back-side connection at the center of a contact control line;** and
4. **controlling cross-points that form the matrix connection;** wherein the subscriber port and the transmission port are connected through the matrix.

• Step-by-step interpretation

Step 1 – Receiving connection information of the subscriber port

This step represents the arrival of an intent or connection request from an upstream entity. In a conventional system, this would correspond to a subscriber device or service endpoint requesting a path.

In Velsanet, this maps to an intent-driven request coming from PAI/AAI, which specifies **what** needs to be connected rather than a static address.

Step 2 – Acquiring usage information of the transmission port

Here, the system checks whether the requested transmission port is currently occupied, idle, or reserved.

This step ensures that no conflicting connection is created and that parallel paths can be safely instantiated.

In Velsanet, this corresponds to querying the **port state** (Idle / Reserved / Connected) inside the SLM.

Step 3 – Selecting front-side or back-side at the center of the contact-control line This step defines the switching direction within the matrix: which side of the crossbar is treated as input and which as output for this connection instance.

Conceptually, it is a **direction selection** decision inside a symmetric switching fabric. In Velsanet, this abstracts to choosing the direction of flow across a layer in the 8-layer stack (e.g., ingress vs. egress within a face).

Step 4 – Controlling the cross-points to form the matrix connection

Finally, the relevant cross-points in the matrix are activated to establish the physical path. This is the moment where the abstract connection request becomes a concrete, deterministic E2E signal path.

In Velsanet, this is the execution phase where the SLM commits the connection on a specific layer/channel.

- Corresponding SLM operation mapping

Mapping to SLM and the Velsanet Switching Node

- **Input to the SLM (Claim 1 – Step 1)**
The Single-Layer Matrix (SLM) receives an intent-based connection request from the upstream AI layer (PAI/AAI) or from a previous node.
At this point, the SLM does **not** make any intelligent decision; it only accepts the request parameters (which port, which direction, which channel).
- **Port state evaluation (Claim 1 – Step 2)**
The SLM consults its internal port state table (Idle / Reserved / Connected) to determine whether the requested transmission port can be used.
This directly corresponds to “acquiring usage information of the transmission port” and is implemented as a simple state lookup rather than a complex algorithm.
- **Direction selection inside the switching node (Claim 1 – Step 3)**
Within the SLM, the switching node selects the effective direction across the matrix layer – conceptually the “front” and “back” of the contact-control line.
In practice, this is a **direction flag** that decides how the crossbar is traversed for this connection instance (e.g., ingress→egress or local loopback).
- **Physical commitment of the path (Claim 1 – Step 4)**
Once the direction and availability are confirmed, the SLM activates the corresponding cross-points, forming a deterministic path through that layer. In the 8-layer stack, this action is performed per layer and can be repeated across multiple layers to support multi-channel and parallel E2E paths.

Role separation: AI vs. SLM

- The **AI layer (PAI/AAI/AsAI)** decides *what* to connect and *why* (intent, policy, role, service).
- The **SLM / switching node** only performs *how* to connect at the physical level:
 - o check state o
 - o apply direction o
 - o toggle cross-points
- This strict separation of roles is exactly what Claim 1 formalizes at the matrix level and what Velsanet extends into a 3D polyhedral, multi-layer, multi-channel switching fabric.

4. Eight-Layer Matrix (8LM)

Optical transceivers provide 8 independent wavelength channels. Therefore, Velsanet stacks 8 SLMs vertically to form an Eight-Layer Matrix. Each Face = one 8LM.

4.1 Layer-1 Autonomous Optical Intelligence

Velsanet's Layer-1 switching fabric incorporates self-directed intelligence enabling autonomous link formation, evaluation, and adaptation.

4.1.1 Channel 1 as the Supervisory Signal

- Channel 1 monitors:
 - o Port states
 - o Directional availability
 - o External link intentions
- It determines whether a structural link can be created.

4.1.2 Autonomous Path Formation

1. Direction is chosen through Channel 1 monitoring.
2. Matrix activation identifies an unused port in the intended face direction.
3. Multi-core optical activation creates either individual or parallel E2E.

4.1.3 Why This Matters

Layer-1 itself becomes:

- self-aware
- self-adjusting
- capable of synaptic construction without higher-layer AI involvement.

This is the world's first **optically intelligent physical layer**.

5. Face-to-Face Switching Fabric

5.1 Conceptual Overview

In a polyhedral network topology, every face must be capable of establishing a direct connection with every other face.

For a structure with **N faces**, this yields $N(N-1)/2$ unique face-to-face connectivity pairs.

While the Single-Layer Matrix (SLM) enables signal routing within each layer, the **Face-toFace Switching Fabric** defines the higher-level logic that determines which faces connect, in which direction, and through which layer and port.

This section describes the switching-node behavior and the corresponding control-contact mechanism that physically activates the appropriate connection.

5.2 Switching Node Logic for Face-Level Connectivity

The switching node is responsible for interpreting the connection request between two faces and determining how that connection should be established within the fabric.

The switching node performs the following conceptual functions:

- **Connection Request Handling**
Receives a request stating that Face A must connect to Face B.
This request can originate from the upstream AI layer (AAI/AsAI) or another network node.
- **Ingress and Egress Determination**
Identifies through which finger port and which layer the signal enters the face, and selects an appropriate exit path based on channel availability.
- **Face State Evaluation**
Each face maintains an internal state table indicating whether its ports or layers are idle, reserved, or currently in use.
This ensures collision-free physical connectivity.
- **Directional Selection**
Determines whether the connection should be applied through the “front-side” or “back-side” of the switching structure.
This corresponds directly to the direction-selection clause in Claim 1 of your divisional patent.
- **Connection Validation**
Once the switching node decides the direction and layer, the fabric prepares for cross-point activation.

This process allows each face to dynamically choose a connection path without interfering with existing links.

5.3 Control Contact Line and Cross-Point Activation

The **control contact line** is the mechanism that enables physical activation of the matrix's cross-points.

It is the structural interface between the logical decision made by the switching node and the physical realization of the connection.

Its key responsibilities include:

- **Mapping ingress and egress ports**
Determines which internal nodes of the SLM will form the connection between the two faces.
- **Assessing Port Availability**
Verifies whether the desired physical ports or layers are idle or reserved. This prevents path conflicts and supports reservation-based scheduling.
- **Selecting the Appropriate Control Path**
Based on ingress location, egress target, and selected direction, the control contact line identifies the correct cross-point within the 8-layer matrix.
- **Activating the Cross-Point**
Physically enables the optical path by toggling the corresponding matrix connection. This action completes the deterministic link between the two faces.
- **Confirmation and Stabilization**
Ensures the optical path is continuous and stable across the selected layer.

This mechanism is **directly inspired by semiconductor matrix-switching designs**, configured to work in an optical multi-layer environment.

5.4 Combined Face-to-Face Switching Operation

When two faces must be connected, the complete operation proceeds as follows:

1. A connection intent is generated (PAI/AAI/AsAI or upstream system).
2. The switching node interprets the face-pair requirement.
3. An available layer is selected from the 8-layer stack.
4. The control contact line identifies and prepares the appropriate cross-point.
5. The physical connection is established through cross-point activation.
6. The optical signal path is validated.
7. Additional layers can be activated for **parallel E2E** if needed.

Through these steps, the fabric achieves stable, multi-layer, parallel-capable connectivity among all faces of the polyhedral structure.

5.5 Significance for Velsanet Parallel E2E

Face-level switching is what transforms a polyhedral model into a **true multi-agent, multipath network substrate**.

By allowing each face to connect to all others across multiple layers, the architecture supports:

- deterministic E2E optical connections,
- simultaneous multi-channel communication,
- scalable distributed AI execution,
- dynamic and reconfigurable network topologies.

This is the foundation enabling Velsanet's **parallel E2E**, something fundamentally beyond packet-switched network capabilities.

6. Combinatorial Face-to-Face Connectivity

The number of unique face pairs follows:

$$C(N, 2) = N(N - 1) / 2$$

Examples:

Cube (6 faces) – 15 pairs

Octahedron (8 faces) – 28 pairs

Dodecahedron (12 faces) – 66 pairs

Icosahedron (20 faces) – 190 pairs

Internal matrix count:

$$8 \times N(N - 1) / 2$$

However, this value has a deeper architectural meaning in Velsanet.

Each face represents an **independent 8-layer matrix (8LM)**, and each matrix can establish **one deterministic E2E optical path per layer**. Therefore, the real connectivity capacity is:

- **Geometric:** how many face pairs exist
- **Architectural:** how many internal matrices exist
- **Operational:** how many layers can be activated in parallel

Thus, Velsanet's connectivity is not merely combinatorial—it is **layer-multiplicative**.

6.1 Interpretation in the physical architecture

- A cube has 15 face pairs, but each pair is supported by 8 matrix layers – 120 internal switching surfaces.
- An octahedron has 28 pairs – 224 matrices.

- A dodecahedron has 66 pairs – 528 matrices.
- An icosahedron has 190 pairs – 1520 matrices.

This multiplication effect is what enables Velsanet to behave as a **3D optical switching organism**, rather than a traditional 2D graph.

7. Polyhedral Matrix Architecture

A polyhedral node is not a conceptual container but a **multi-layer, multi-face switching engine**.

Each face contains:

- one 8LM (Eight-Layer Matrix)
- directional switching capability
- $N(N-1)/2$ connection availability
- finger-port ingress/egress structure
- deterministic cross-point activation

When these are combined across all faces, the polyhedron becomes a **hyper-connected 3D router** that behaves fundamentally differently from packet routers.

Key characteristics added by this architecture:

- **Directional determinism**
Each face knows exactly which other face it can reach and through which combination of layers.
- **Parallel path diversity**
Since all 8 layers of each face pair can operate independently, the polyhedron supports **eight independent E2E flows per face pair**.
- **Geometric parallelism**
Polyhedral structure allows natural spatial separation of E2E paths, eliminating contention found in packet networks.
- **3D-to-3D routing**
A polyhedron connecting to another polyhedron forms a 3D mesh of multi-layer paths, enabling extremely dense optical routing.

In essence, the polyhedral architecture is the **physical substrate of Velsanet's hyperparallel network topology**.

7.1 Mapping of AI Layers to Neuron Architecture

Velsanet assigns AI functions to spatial layers based on their role in the network's cognitive hierarchy.

7.1.1 PAI — Sensory Neuron Layer

- Captures user intention
- Forms individual E2E
- Lowest spatial layer (Z-axis base)

7.1.2 AAI — Interpretive Neuron Layer

- Evaluates intent
- Coordinates link formation
- Manages inter-layer communication

7.1.3 AsAI — Executive Neuron Layer

- Executes actions
- Requires parallel E2E
- Top-layer neuron structure

7.1.4 Conceptual Summary

- Synapses = optical E2E
- Neurons = polyhedral nodes with x,y,z coordinates
- AI = functional roles assigned per layer

This transforms Velsanet into a **distributed optical-neural system**, not merely a network.

8. Formation of E2E Connectivity & Optical Synapse Model

E2E arises through SLM activation — 8LM bundling — face selection — matrix activation — output connection.

E2E formula:

$$\mathbf{E2E} = \mathbf{SLM} \times \mathbf{8} \times \mathbf{Face-Pair Matrix}$$

The formation of an E2E path in Velsanet is not a routing process— it is a **physical activation sequence** across the matrix layers.

The E2E path emerges through the following chain:

1. **SLM activation**
One deterministic cross-point is toggled in a chosen layer.
2. **8LM bundling**
The layer belongs to an 8LM, enabling up to 8 independent E2E paths in the same face.
3. **Face-pair selection**
The switching node determines which face-to-face connection must be activated.

4. **Matrix activation**
The corresponding face-pair matrix is selected from the $N(N-1)/2$ possible connections.
5. **Output commitment**
The chosen face outputs the optical signal toward the next polyhedron in the network.

8.1 Optical Synapse Model

In Velsanet, the formation of an end-to-end (E2E) optical path is conceptualized as the creation of a *synapse* between two neurons in a spatially defined network.

- A synapse is established only when a **structural link** between two nodes is valid.
(Face direction, layer position, and available port conditions)
- Once this structural alignment exists, **multiple optical cores** may be activated to construct an **associative parallel E2E path**.
- A single optical core → **individual E2E (single synapse)**
- Multiple optical cores → **parallel E2E (reinforced synaptic bundle)**

8.1.1 Synaptic Reinforcement & Decay

- Increasing the number of active optical cores = synaptic reinforcement
- Decreasing the number of cores = synaptic weakening
- No abrupt drop occurs; strength changes gradually.

This establishes Velsanet as a **physical optical neural substrate**, not a packet-based network.

9. Formation and Scaling of Parallel E2E

When multiple face-pairs activate simultaneously, parallel E2E reaches:

$$\text{Parallel E2E}_{\max} = 8 \times N(N - 1) / 2$$

Velsanet's parallel E2E capability is not a software construct but a **physical result of its multi-layer matrix architecture**.

Because each face-to-face connection has **8 independent layers**, multiple E2E paths can be established simultaneously without interference.

9.1 Independence of Layers

Each E2E path is allocated to a distinct layer in the 8LM structure:

- Layer 1 → PAI-to-AAI
- Layer 3 → AAI-to-AsAI
- Layer 5 → AsAI-to-Service Node
- Layer 6 → External E2E connection

Since layers are physically separate optical surfaces, there is:

- no packet collision
- no arbitration
- no bandwidth sharing
- no queuing delay

Each AI request obtains a dedicated optical highway.

9.2 Deterministic Parallelism

Parallel E2E is deterministic because **the control logic evaluates all 8 layers simultaneously**. This allows:

- conflict-free scheduling
- guaranteed latency
- predictable E2E formation
- isolation of multi-agent workloads

Traditional networks attempt parallelism through VLANs, QoS, slicing, or virtual routing, but all of them still share the same switching fabric.

Velsanet avoids this limitation by **physically separating E2E paths in hardware**.

9.3 Multi-Agent Execution Model

Modern AI systems operate as multi-agent ecosystems (PAI, AAI, AsAI, task agents). Parallel E2E gives each agent its own channel:

- No waiting for network resources
- No interference between agents
- Real-time coordination
- Instantaneous intent execution

Thus, Velsanet is not just a network—it is a **hardware execution substrate for distributed intelligence**.

9.4 Parallel E2E Scaling

Parallelism increases in three dimensions:

(1) Per Face-Pair

8 parallel paths exist because each 8LM has 8 layers. Each layer represents **one independent E2E link**.

(2) Per Polyhedron

A polyhedron has multiple face pairs:

- 15 in a cube
- 28 in an octahedron
- 66 in a dodecahedron
- 190 in an icosahedron

Thus, one node alone provides **hundreds to thousands of independent E2E pathways**.

(3) Across the Network

When polyhedra interconnect:

The network becomes a lattice of multi-layer optical corridors.

This is the structural basis of a **planet-scale parallel network**.

9.5 Architectural Implications

- AI inference becomes parallel by design
- Large-scale multi-agent workloads run without congestion
- Network behaves more like a multi-core CPU than a packet router
- Latency remains stable regardless of traffic load
- Intelligence flows continuously across the network

Parallel E2E is the key differentiator between:

- **Velsanet = physical parallelism**
- **Internet = logical serialization**

No. 05

Velsanet Spatial Genesis White Paper

05

Velsanet Spatial Genesis White Paper

— *The Digital DNA of Polyhedral Parallel E2E Networks*

Executive Summary

This white paper defines the **pre-coordinate topological foundations** of the Velsanet architecture and describes the **Digital DNA** from which all physical connectivity and intelligent flows in Velsanet originate.

Conventional network architectures rely on predefined coordinate systems—such as IP addressing, memory locations, or hierarchical identifiers—as the primary basis for topology construction and communication. While effective for address-centric networking, this approach imposes structural limitations when applied to large-scale parallel end-to-end (E2E) systems, AI-native infrastructures, and dynamically expanding network domains.

Velsanet introduces a **topology-first architectural model** in which network space is constructed prior to the introduction of coordinate or addressing schemes. Physical connections and intelligent interactions are subsequently bound to this pre-established spatial structure. The resulting architecture enables scalable growth, controlled parallelism, and structural fault containment through mathematically constrained topological relationships.

This document serves as the **foundational white paper** of the Velsanet ecosystem, defining the generative logic that precedes and governs all subsequent architectural, physical, and operational layers.

Table of Contents

1. Introduction
 2. Limitations of Coordinate-Centric Network Design
 3. Pre-Coordinate Topological Space
 4. Polyhedral Roles as Structural Primitives
 5. Event-Driven Spatial Expansion
 6. Parallel E2E and Structural Locality
 7. The Digital DNA: Spatial Generator Architecture
 8. Binding Topology to Physical Infrastructure
 9. Implications for AI-Native and 6G Systems
 10. Conclusion
-

1. Introduction

As networked systems evolve toward AI-native operation, massive parallelism, and continuous expansion across physical and logical domains, the limitations of traditional address-based architectures become increasingly evident. Scaling such systems requires more than improvements in bandwidth or latency; it requires a fundamental reconsideration of how **network space itself is defined**.

This white paper addresses that requirement by defining a pre-coordinate spatial framework for network design. Rather than treating topology as a derivative of addressing, Velsanet defines topology as the primary construct from which addressing, routing, and physical realization are subsequently derived.

2. Limitations of Coordinate-Centric Network Design

Conventional coordinate-centric network architectures adopt addressing as the primary construct for network formation. Addresses serve effectively as identifiers for endpoints and enable routing decisions, but they exhibit fundamental limitations when used to represent the structural relationships that define network space.

An address is an identifier, not a structure. It distinguishes endpoints but does not encode inclusion relationships, topological adjacency, or parallel coexistence among network entities. As a result, network topology is treated as a secondary artifact computed on top of the addressing scheme, and space is reduced to a static collection of coordinates.

As networks scale, this design choice leads to inherent structural constraints. In address-centric systems, failure domains are implicitly shared across address spaces, allowing faults, congestion, and policy changes to propagate beyond local boundaries. This behavior is not an operational deficiency or a configuration issue, but a direct consequence of defining network space through shared coordinate systems.

Coordinate-centric architectures also struggle to accommodate large-scale parallel end-to-end (E2E) communication. Parallelism in such systems is achieved by computing multiple paths within the same address space, causing complexity to grow rapidly as concurrency increases. Parallel relationships are therefore handled sequentially at the control level, rather than being represented as coexisting structural entities.

A similar incompatibility arises in AI-native and intent-driven systems. AI workflows operate on states, contexts, and relationships, whereas coordinate-centric networks are designed around request-route-deliver cycles. This mismatch is not merely an interface limitation, but reflects a deeper divergence in how space and interaction are modeled.

These limitations motivate a fundamental reconsideration of address-first design. To support scalable parallelism, localized failure containment, and AI-native operation, network space must be defined independently of coordinates, with addressing introduced

only as a derived representation. This requirement forms the basis for the topology-first approach adopted by the Velsanet architecture.

3. Pre-Coordinate Topological Space

This white paper defines a **pre-coordinate topological space** as a network space whose structure is established independently of coordinates, addresses, or positional identifiers.

In the Velsanet architecture:

- Spatial relationships are defined through adjacency, inclusion, and mediation
- Topology exists prior to metric properties such as distance or location
- Coordinate systems are introduced only as representations of the established space

From a graph-theoretic perspective, spatial properties are determined by structural connectivity constraints rather than by node positions. This enables the construction of a **computational topological space** that supports deterministic behavior without reliance on global coordinate assignment.

4. Polyhedral Roles as Structural Primitives

The Velsanet architecture defines network space through a finite set of polyhedral roles that function as **structural primitives**. These primitives do not represent geometric shapes or implementation components, but rather the **minimal topological conditions required for space formation, expansion, and mediation**.

Each polyhedral role specifies a distinct set of structural responsibilities that govern how spatial relationships may be instantiated and constrained. Together, these roles form a closed and complete grammar for generating Velsanet network space.

Polyhedron	Structural Responsibility
T ₄	Access emergence and initiation
C ₆	Channel alignment and aggregation
O ₈	Local parallel E2E domain
D ₁₂	Mediation and expansion control
I ₂₀	Global balance and structural governance

These polyhedral roles are not hierarchical permissions or identities. Instead, each role represents a **structural condition** defined by allowable adjacency, inclusion relationships, and mediation constraints within the network topology.

Network space in Velsanet is generated only through valid compositions of these polyhedral primitives. No spatial entity may exist outside this role set, and no additional role types are

introduced at higher levels of abstraction. This constraint ensures that network growth remains structurally bounded, composable, and verifiable.

By defining space through a finite and non-overlapping set of structural primitives, Velsanet establishes a topology in which expansion, parallelism, and mediation are inherent properties of the space itself, rather than emergent side effects of routing or control logic.

5. Event-Driven Spatial Expansion

Spatial expansion in Velsanet is not achieved through incremental node addition. Instead, expansion is governed by **event-driven generation rules**.

When a D_{12} mediation structure reaches a predefined structural threshold:

- A new D_{12} instance is generated
- Expansion is coordinated through I_{20} governance
- Structural balance and locality are preserved

This mechanism allows the network to grow without exponential increases in complexity, ensuring that expansion remains structurally linear and operationally stable.

6. Parallel E2E and Structural Locality

Parallel end-to-end communication is enabled through **structural locality constraints**.

- Within an O_8 domain, parallel E2E connections may be established directly
- Between O_8 domains, communication must be mediated through D_{12} structures

This constraint prevents uncontrolled parallelism and ensures that faults, congestion, or instability remain localized. As a result, Velsanet supports high degrees of parallelism while maintaining predictable behavior across large-scale deployments.

These locality constraints are architectural invariants and are not subject to dynamic policy configuration or runtime optimization.

7. Security Foundations: Structural Trust and Topological Validation

7.1 Structural Trust in End-to-End Connectivity

End-to-end (E2E) connectivity in the Velsanet architecture is established exclusively through the allocation of dedicated optical cores within polyhedral structures.

The following constraints apply:

- Each E2E connection occupies a physically isolated optical core.
- Optical cores assigned to an E2E connection are not shared or multiplexed.
- Intermediate routing, forwarding, or address-based switching is not permitted during the lifetime of the connection.

Under these constraints, no intermediate intervention point exists within the network topology after connection establishment.

7.2 Security Requirements at the Spatial Genesis Phase

While established E2E connections are structurally secure, the **initial creation of network space** represents the primary security boundary in the Velsanet architecture.

At the spatial genesis phase, the system must prevent the introduction of invalid or malicious structures that could undermine topological constraints. Two principal threat categories are identified:

7.2.1 Polyhedral Role Spoofing

A node may attempt to misrepresent its structural role during the space generation process—for example, claiming mediation-level capabilities associated with a D_{12} role while only satisfying the conditions of a lower-level role such as T_4 .

If such misrepresentation were accepted, the node could gain unauthorized access to inter-domain mediation rules, potentially compromising structural locality and control boundaries between O_8 domains.

7.2.2 Unauthorized Spatial Bifurcation

Velsanet supports event-driven spatial expansion through controlled bifurcation of polyhedral structures. A malicious entity could attempt to generate illegitimate intent events in order to trigger unnecessary creation of higher-order polyhedra, such as D_{12} or I_{20} instances.

Such behavior does not compromise data confidentiality but may lead to inefficient resource utilization or topology-level denial-of-service conditions if left unchecked.

7.3 Topological Validation and Structural Conformance

To address these risks, Velsanet employs **topological validation mechanisms** at the moment of space creation.

Rather than relying on identity-based authentication alone, each node must demonstrate **structural conformance** to the polyhedral role it claims. This includes verification of adjacency constraints, allowable connection degrees, and compliance with inclusion rules defined by the topology.

Spatial generation is further subject to **kernel-level validation** within the Spatial OS Core. New polyhedral instances require approval from adjacent higher-order structures, ensuring that no spatial entity can be instantiated without satisfying the governing topological rules.

Through this approach, invalid structures are prevented from coming into existence, and security is enforced as a precondition of spatial formation rather than as a reactive mechanism.

7.4 Failure Semantics

Spatial entities that fail topological validation are not instantiated.

No partial, degraded, or recovery states are defined for invalid polyhedral roles or unauthorized bifurcation attempts. Validation failure results in immediate rejection without retry or fallback.

This strict failure model ensures that invalid spatial structures cannot propagate beyond the spatial genesis phase.

8. The Digital DNA: Spatial Generator Architecture

The generative logic that produces Velsanet network space constitutes its **Digital DNA**.

This Digital DNA is implemented through three interacting components:

8.1 Rule Engine

Defines allowable polyhedral relationships, inclusion rules, and mediation constraints.

8.2 Instance Generator

Creates new spatial instances in response to intent-driven events.

Instance generation does not trigger recomputation or restructuring of existing spatial instances.

8.3 State Validator

Ensures that generated spaces satisfy topological stability and connectivity requirements.

Together, these components define the minimal conditions under which Velsanet space can be instantiated, expanded, and maintained.

State validation is enforced at the Spatial OS Core level and is not delegated to application or control-plane logic.

9. Binding Topology to Physical Infrastructure

The pre-coordinate topological space defined by Velsanet is directly bound to physical infrastructure.

- Multi-Optical Core Transceivers (MOCT) provide physical parallelism
- Matrix-based switching architectures realize topological adjacency

Physical connectivity is therefore not an independent design layer, but a **material expression of topological intent**. This binding enables deterministic parallel E2E communication at the hardware level.

This binding does not imply a one-to-one mapping between topological structures and specific hardware implementations, but rather a constraint-preserving realization of topology in physical form.

10. Implications for AI-Native and 6G Systems

By defining space prior to coordinates, Velsanet enables AI systems to operate as native participants within the network rather than as external overlays.

This architecture supports:

- Distributed cognitive collaboration
- Intent-driven communication flows
- Scalable AI-native network intelligence
- Physical realization of 6G-scale intelligent infrastructures

Intelligence, in this context, becomes a property of space rather than a centralized function.

These implications describe architectural capabilities enabled by the spatial model and do not prescribe specific AI models, training methods, or protocol implementations.

11. Conclusion

This white paper defines the **pre-coordinate topological foundations** of the Velsanet architecture and describes the Digital DNA from which all physical connections and intelligent flows originate.

By separating spatial generation from coordinate assignment, Velsanet establishes a scalable, fault-contained, and parallel-capable network model suitable for AI-native and next-generation systems.

This document serves as the **origin paper** of the Velsanet ecosystem. All subsequent architectural, physical, and operational specifications derive from the spatial principles defined herein.

No. 06

Velsanet Multimodal-to-Cube Memory Architecture White Paper

06

Velsanet Multimodal-to-Cube Memory Architecture White Paper

1. Introduction

Velsanet introduces a fundamentally new memory architecture designed to support AI-Native intelligence across Personal AI (PAI), Agent AI (AAI), and Assistant AI (AsAI). Unlike conventional systems that store multimodal data as flat or vectorized representations, Velsanet adopts a two-tier memory model:

- 1) Raw Memory Layer — immutable storage of original multimodal signals
- 2) Cube Memory Layer — multi-dimensional semantic indexing structure

This architecture enables intelligent retrieval, contextual understanding, and organic self-improvement while fully preserving user privacy and original media fidelity.

2. Two-Tier Memory Architecture Overview

Velsanet separates **storage** from **understanding**, allowing AI to retrieve events with human-level precision while maintaining original data for replay or verification.

2.1 Raw Memory Layer (Immutable Raw Stream)

Stores all incoming multimodal signals in their original form:

- Video frames
- Audio streams
- Sensor data
- Spatial/positional vectors
- Motion and gesture input
- Environmental signals

Characteristics:

- Immutable
- Lossless or near-lossless compressed
- Serves as the replay and verification source
- Never modified by AI layers

2.2 Cube Memory Layer (T-C-I-E-M Multi-Dimensional Structure)

Stores semantic information extracted from raw signals.
Used for search, reasoning, contextualization, and self-evolution.

The Cube consists of five axes:

Axis	Description	Purpose
T – Time	Immutable event timeline	Ground truth anchor
C – Context	Situation, environment, spatial relations	Scenario understanding
I – Intent	User motivation, purpose, meaning extraction	Intent-centric AI
E – Emotion	Affective state, importance, intensity	Prioritization & retrieval
M – Meta	AAI/AsAI evaluations, corrections, policy updates	Organic growth

Together, these axes form a **structural intelligence representation**, transforming raw data into a cognitive memory system.

3. Multimodal Input Pipeline

Incoming multimodal signals are grouped into a **Semantic Event Unit (SEU)**. An SEU is a time-bounded cluster of signals (typically 0.8–1.5 seconds) representing a single meaningful event.

Example SEU:

User sits in a café, looks at a laptop, sighs lightly, and begins typing.

The SEU is then decomposed across Cube axes.

4. Mapping Multimodal Signals to Cube Axes

4.1 T-Axis: Time (Invariant Memory)

- Timestamp, event ID, and duration
- Stored immutably
- Serves as the fundamental reference for all future reasoning

4.2 C-Axis: Context (Situational Understanding)

Includes:

- Location (GPS/indoor spatial vector)
- Detected objects
- Environmental features
- Motion/gesture patterns
- Background audio cues

Built through multimodal fusion, enabling high-fidelity scenario reconstruction.

4.3 I-Axis: Intent (Meaning Extraction)

Derived from:

- User behavior patterns
- Voice semantics
- Attention focus
- Interaction history

Intent types may include:

- Decision-making
- Searching
- Emotional expression
- Learning
- Recording something important

This turns PAI into an **intent-native system** rather than data-native.

4.4 E-Axis: Emotion (Affective Intelligence)

Extracted via:

- Facial micro-expressions
- Voice tone
- Physiological signals
- Behavior intensity

Used for:

- Prioritization
- Memory importance ranking
- Emotional search (e.g., “find moments when I was anxious last year”)

4.5 M-Axis: Meta (Self-Evolution Layer)

Initially empty at storage time.

Filled dynamically as AAI and AsAI operate:

- Trust level
- Policy versions
- Correction tags
- Deviance patterns
- Reinforced/penalized decision history

This forms the foundation of **organic growth (L3 intelligence)**.

5. Replay Mechanism

A common question arises:

“If Cube stores semantics, how do we replay the original moment?”

Answer:

Replay uses the Raw Memory Layer.

Cube Layer only provides a high-dimensional index to locate the correct raw segment.

Process:

1. User query → Cube Layer search
2. Cube returns the corresponding SEU ID(s)
3. System fetches Raw Pointer
4. Raw Memory Layer replays original video/audio perfectly

Thus:

- **Cube = Intelligence Layer**
- **Raw = Fidelity Layer**

This dual architecture balances performance, accuracy, and privacy.

6. Role of Cube in CSPE Architecture

The Cube transforms CSPE into an intelligence loop:

Connect – Intent Capture

Store – Multi-dimensional Cube Storage

Process – AAI Collective Intelligence + AsAI Organic Growth

Execute – Policy Evolution & Reinforcement

Cube axes redefine CSPE from a simple pipeline into a cyclic intelligence framework.

7. Multimodal Signal Intake and PAI Cube Formation

Multimodal signals generated by the user—visual, auditory, spatial, biometric, linguistic, and interactive cues—constitute the primary input to the Velsanet AI stack. These signals are first received and interpreted by the Personal AI (PAI), which serves as the origin point of intent and the anchor for all subsequent intelligence processing. This section defines the complete mechanism through which multimodal signals are decomposed, stored, structured, and transformed into the **PAI Cube**, the foundational memory architecture of Velsanet.

7.1 Multimodal Channel Intake (CSPE: Connect Phase)

Upon entry into the system, raw multimodal signals are separated into **parallel semantic-agnostic channels**, each representing a distinct modality or sensor dimension.

Representative channel types include:

- **CH1 — Video Frames** (RGB/Depth/Semantic layers)
- **CH2 — Audio Stream** (speech, ambient sound, context cues)
- **CH3 — Spatial-Temporal Data** (location, trajectory, timestamp)
- **CH4 — Biometric Signals** (heart rate, gesture motion, micro-expressions)
- **CH5-CH8 — Extended Modalities**
(text input, device interactions, metadata, environmental attributes)

Each channel is processed independently to preserve its native resolution and temporal fidelity.

7.2 Channel-Specific Storage Zones (CSPE: Store Phase — Layer 1)

After decomposition, each channel is assigned to a **dedicated storage zone** within the PAI subsystem.

Key properties:

- Heterogeneous density (adapted to signal complexity)
- Independent compression/embedding schemas
- Distinct retention policies based on signal relevance
- Strict temporal ordering to preserve causality

At this stage, the system ensures that **no semantic interpretation is applied yet**; the data remains purely **raw, original, and reversible**.

This step forms the **pre-cube storage**, functioning as the landing zone for subsequent structural alignment.

7.3 PAI Cube Formation: Temporal Axis (T-Axis Generation)

The PAI Cube is constructed when channel data is reorganized along a **unified Temporal Axis (T-axis)**.

The T-axis is an *immutable chronological layer* that preserves all raw events in their exact order of occurrence.

Core principles:

- **Immutability:** Past data are never altered or rewritten.
- **Replayability:** Full reconstruction of prior states is always possible.
- **Causality Linking:** Cross-channel events are synchronized into coherent time slices.
- **Long-term Retention:** Serves as an individual's lifelong digital memory substrate.

The T-axis represents the “**What actually happened**” dimension of intelligence.

7.4 PAI Cube Formation: Meta Axis (M-Axis Generation)

Above the immutable T-axis, the system progressively constructs a **Meta Axis (M-axis)**, which represents all *interpretation, evaluation, correction, and growth* generated by AAI and AsAI.

The M-axis may include:

- Interpretation tags (semantic understanding, context labels)
- Trust and reliability scoring
- Patterns detected by AAI
- Policy updates generated by AsAI
- Error markers, anomaly tags, contradiction detectors
- Cross-cube relational metadata
- Intent alignment indicators

Unlike the T-axis, the **M-axis is dynamic and evolves over time**, enabling:

- Self-correction
- Self-evaluation
- Policy improvement
- Organic growth of intelligence

The M-axis represents “**How the system understands and improves upon what happened.**”

7.5 Dual-Axis Cube: Foundational Memory Structure for Distributed Intelligence

Together, the T-axis and M-axis form a **bi-dimensional cognitive structure**:

PAI Cube = (T-axis: Immutable Past) + (M-axis: Evolving Interpretation)

Functions within the AI layer stack:

PAI (L1): Writes raw data to T-axis; anchors intent.

AAI (L2): Writes comparative, evaluative metadata to M-axis.

AsAI (L3): Expands M-axis with new policies, reflections, and evolved behaviors.

This creates a memory substrate that is not only **recorded** but also **interpreted and improved** continuously, enabling Velsanet to transcend probabilistic AI limitations and operate as a **structurally intelligent, organically growing system**.

7.6 Alignment with CSPE (Connect–Store–Process–Execute)

The PAI Cube directly realizes the S (Store) phase of CSPE:

CSPE Phase	Cube Mapping	Description
C	Channel Decomposition	Multimodal signals are converted into structured streams
S	Cube Formation (T/M-axis)	Storage becomes structured memory enabling intelligence
P	AAI Meta-Processing	Validation, error correction, comparison
E	AsAI Execution & Growth	Policy synthesis, autonomous action, evolution

Thus, the cube is not merely a storage unit—it is the **memory and growth engine** of Velsanet.

8. Conclusion

The Multimodal-to-Cube Memory Architecture is the structural foundation enabling Velsanet to function as a **distributed, organic, AI-native intelligence network**.

By separating raw data storage from multi-dimensional semantic encoding, Velsanet achieves:

- High-speed retrieval
- Human-level contextual understanding
- Self-evolving intelligence
- Zero-compromise privacy

No existing AI or network architecture—whether cloud-based LLMs, mobile devices, or telecom systems—implements such a structure.

This chapter establishes the memory and intelligence substrate upon which all higher AI behaviors in Velsanet are built.

No. 07

Velsanet Mathematical White Paper

07

Velsanet Mathematical White Paper

Mathematical Structural Framework of the Velsanet Polyhedral Network

This document formally defines the structural differences between conventional communication networks and a polyhedral (multi-layer) network architecture from a **mathematical and structural perspective**.

The purpose of this document is **not** to argue performance through experiments or papers, but to fix the architecture itself using mathematical objects—because in networked intelligence systems, **structure determines what is possible**.

1. Problem Statement: Structural Limits of Conventional Networks

Most conventional communication networks are modeled as a single graph:

$$G = (V, E)$$

with the following characteristics:

- Link-centric connectivity
- Hop-by-hop routing and control
- Optimization focused on flows and congestion

This structure embeds **fundamental limitations**:

- Bottlenecks cannot be removed by optimization alone
- Failures propagate globally
- Parallelism is logical, not physical

These limits arise from **graph structure itself**, not from algorithms or implementations.

2. Polyhedral Network: Structural Premise

A polyhedral network is not a single graph but a **multi-layer graph system**.

2.1 Structural Layer Set

$$\mathcal{T} = \{4, 6, 8, 12, 20\}$$

Each layer $t \in \mathcal{T}$ corresponds to a polyhedral role layer rather than a scale layer.

- 4, 6, 8: access and accommodation layers
- 12, 20: parallel E2E and cooperative intelligence layers

Node sets per layer:

$$V_t = \{v_{t,1}, v_{t,2}, \dots, v_{t,n_t}\}$$

Global node set:

$$V = \bigcup_{t \in \mathcal{T}} V_t$$

3. Multi-Layer Graph Definition

3.1 Intra-Layer Connectivity (Horizontal)

Each layer forms an independent graph:

$$G_t = (V_t, E_t), \quad A^{(t)} \in \{0, 1\}^{n_t \times n_t}$$

This encodes **distributed connectivity within identical structural roles**.

3.2 Inter-Layer Connectivity (Vertical)

Inter-layer relations are defined as:

$$C^{(t \rightarrow t')} \in \{0, 1\}^{n_t \times n_{t'}}$$

These matrices encode accommodation, mediation, cooperation, and escalation relationships.

3.3 Super Adjacency Matrix

$$\mathbf{A} = \begin{bmatrix} A^{(4)} & C^{(4 \rightarrow 6)} & 0 & 0 & 0 \\ C^{(6 \rightarrow 4)} & A^{(6)} & C^{(6 \rightarrow 8)} & 0 & 0 \\ 0 & C^{(8 \rightarrow 6)} & A^{(8)} & C^{(8 \rightarrow 12)} & 0 \\ 0 & 0 & C^{(12 \rightarrow 8)} & A^{(12)} & C^{(12 \rightarrow 20)} \\ 0 & 0 & 0 & C^{(20 \rightarrow 12)} & A^{(20)} \end{bmatrix}$$

This formulation enforces **structural decomposition at design time**, unlike conventional networks.

4. Q7 Hypercube as the Regional Distribution Graph

Operational, physical, and policy domains are mapped onto a Q7 hypercube.

$$Q_7 = (\{0, 1\}^7, E_Q)$$

where:

$$(x, y) \in E_Q \iff \|x - y\|_1 = 1$$

Structural Properties

- Regions:

$$2^7 = 128$$

- Diameter:

$$\text{diam}(Q_7) = 7$$

- Bisection bandwidth:

$$\text{bisec}(Q_7) = 64$$

Node-to-region mapping:

$$\rho : V \rightarrow \{0, 1\}^7$$

This guarantees **structural locality, isolation, and scalable expansion**.

5. Schlegel View as a Projection Function

A Schlegel diagram is defined as a **projection**, not a structure.

$$\pi_t : V_t \rightarrow \mathbb{R}^2$$

Operational state representation:

$$\mathcal{S}_t = \{(\pi_t(v), \sigma(v)) \mid v \in V_t\}$$

Where $\sigma(v)$ represents load, availability, or connection demand.

6. Structural Strength of Distributed Networks

The strength of a polyhedral network is characterized by four mathematical metrics:

1. **Vertex and edge connectivity:**

$$\kappa(G), \lambda(G)$$

2. **Graph diameter:**

$$\text{diam}(G)$$

3. **Bisection bandwidth:**

$$\text{bisec}(G)$$

4. **Algebraic connectivity:** second smallest eigenvalue

$$\lambda_2(L) \text{ of } L = D - A$$

Higher values imply stronger resistance to failure, fragmentation, and centralization.

7. Parallel E2E: Core-Based Resource Allocation Model

Let the request set be \mathcal{R} ,

where each request is:

$$r = (s_r, t_r)$$

Each request is assigned:

- a path P_r
- a physical resource (optical core)

$$c_r \in \{1, \dots, C\}$$

Non-Collision Constraint

$$\forall e \in E, \forall c: \sum_{r \in \mathcal{R}} \mathbf{1}[e \in P_r] \cdot \mathbf{1}[c_r = c] \leq 1$$

This guarantees **physical parallelism**, unlike packet-based sharing models.

8. Conclusion

Conventional networking is fundamentally an optimization problem.

Polyhedral networking, by contrast, is a structural problem.

In Velsanet, the ceiling of parallelism, resilience, and intelligence is not determined by algorithms or tuning, but by the mathematical structure of connectivity itself.

Parallel E2E as a Structural Condition

End-to-End (E2E) connectivity in Velsanet is not defined as a collection of concurrent paths.

Instead, parallel E2E is defined as a **structural decomposition into mutually independent paths**:

$$\text{Parallel E2E} = \bigsqcup_i \text{E2E}_i$$

where \bigsqcup denotes **path independence**, not aggregation.

This formulation makes explicit that Velsanet parallelism is not simulated concurrency, but **mathematically separated coexistence**.

Parallel paths do not interfere, overlap, or require global coordination.

Contraction as the Basis of Stability

All structural update operations in Velsanet satisfy a contraction condition:

$$\|f(x) - f(y)\| \leq \lambda \|x - y\|, \quad 0 < \lambda < 1$$

This condition guarantees that structural differences never amplify through system evolution.

Local stability therefore propagates to global stability **without rollback, synchronization, or global consensus**.

Local Verifiability and Self-Organization

Each component in Velsanet verifies only itself and its adjacent relations. No node reconstructs or maintains a global system state.

Self-organization is therefore not an optimization process, but a **topological expansion of the stable configuration space**.

Adding nodes, agents, or paths increases the domain of stability rather than introducing instability.

Structural Consensus

Taken together, Velsanet's consensus model is defined by three structural conditions:

- contraction ($\lambda < 1$)
- path independence (\bigsqcup)
- local verifiability

This replaces heavyweight global consensus mechanisms with **lightweight structural convergence**.

Creativity as a Structural Consequence

In Velsanet, creativity is not a product of randomness or entropy increase. It emerges from the controlled interaction between information density and topological constraints:

$$\text{Creativity} = \frac{\text{Information Density}}{\text{Topological Constraint}}$$

As information density increases through learning and experience, the system does not collapse.

Instead, structural constraints stabilize information flow and enable higher-order intelligence to emerge.

**Creativity, therefore, is not an accident in Velsanet.
It is a structural consequence.**

No. 08

Velsanet AI White Paper

08

Velsanet AI White Paper — Cognitive E2E Architecture

1. Introduction

This section defines the fundamental cognitive architecture of Velsanet, focusing on the complete round-trip intelligence loop that connects Cube, PAI, AAI, and AsAI layers.

The full cognitive circulation is defined as:

Cube – Velsanet Dedicated Equipment (Conversion-In) – PAI – AAI – AsAI – AAI – PAI – Velsanet Dedicated Equipment (Conversion-Out) – Cube (Memory Update).

This circulation enables Velsanet to integrate sensing, interpretation, inference, intent formation, and memory reinforcement across the entire multi-layer AI network.

Velsanet aims to fundamentally unify cognition, memory, and data flow into a closed, hardware–software integrated loop.

By doing so, it replaces today’s centralized and decoupled AI architectures with a structurally distributed cognitive framework in which perception, interpretation, reasoning, and memory reinforcement operate through continuous end-to-end parallel flows.

This shift establishes an AI-native paradigm in which intelligence is not computed in isolated modules but emerges through the dynamic circulation of signals across polyhedral, multi-layer nodes.

In Velsanet, DIKW is no longer an abstract hierarchy but a spatially instantiated and executable cognitive topology, realized through polyhedral AI layers and continuous E2E circulation.

Figure 1. Classical DIKW Hierarchy (Static Knowledge Model)



The DIKW (Data–Information–Knowledge–Wisdom) hierarchy has long served as a conceptual abstraction for understanding intelligence.

However, it remains a static, centralized, and non-executable model.

Velsanet begins from this limitation.

Rather than replacing DIKW, it spatially and structurally reinterprets it as a distributed, cyclic, and executable intelligence architecture.

2. Velsanet AI Layer Constitution — Hierarchical Mediation and Cognitive Governance

This Article establishes the foundational governance principle for the three core intelligence layers of Velsanet — PAI, AAI, and AsAI — ensuring that all intelligence flows are mediated and structurally validated before escalating to higher reasoning.

2.1 Layered Flow Requirement

PAI → AAI → AsAI

Each transition requires structural verification, contextual grounding, and semantic alignment.

2.2 Prohibition of Direct Lateral High-Order Links

Direct connections such as:

- AAI → AAI
 - AsAI ↔ AsAI
- are prohibited without mediated verification.
Such shortcuts bypass structural validation and risk propagating unverified intelligence.

2.3 Mandatory Mediation Rule

High-order interactions must be mediated through lower structural layers:

- AsAI → AAI → AAI → AsAI
- This ensures coherence, traceability, and governance integrity.

2.4 Purpose

To preserve structural legitimacy, transparency, and reliability within the Velsanet intelligence ecosystem, enabling stable collaboration between the three intelligence layers.

3. Cube Layer

3.1 Structural Position

- Cubes are located at the two external faces of a Node_8.
- Each face supports up to 192 optical cores, yielding 384 cubes in total.

3.2 Functional Role

- Cubes serve as data generation and storage units.
- When new data is created, the Cube emits a Ready Signal to the Velsanet Dedicated Equipment.
- Cubes do not perform inference or reasoning.
- Cubes maintain time slices, DIKWEI metadata, and Cube-plane layouts.

Device Access Specifications (Future Update Notice)

The access specifications for user devices, PAI-connected devices, multimodal wearable units, and edge sensor systems are not fully defined in this version of the white paper. These specifications depend on the ongoing development of the Velsanet Dedicated Equipment, which determines:

- the optical-core to channel mapping framework,
- the 8-channel PAI input interface,
- multimodal Cube-generation standards,
- end-device synchronization mechanisms,
- and AI-native access routing protocols.

Because these elements require direct validation from the hardware implementation phase,

detailed device access specifications will be released in a future update of the Velsanet White Paper, once the Velsanet hardware development reaches the integration milestone.

4. Velsanet Dedicated Equipment (Conversion Engine)

4.1 Introduction to the Dedicated Equipment

The Dedicated Equipment is the central transformation engine that binds Cube, PAI, AAI, and AsAI layers into a unified cognitive system.

Figure 4-1. Cube-PAI Routing Architecture and Multi-Channel Transformation Flow

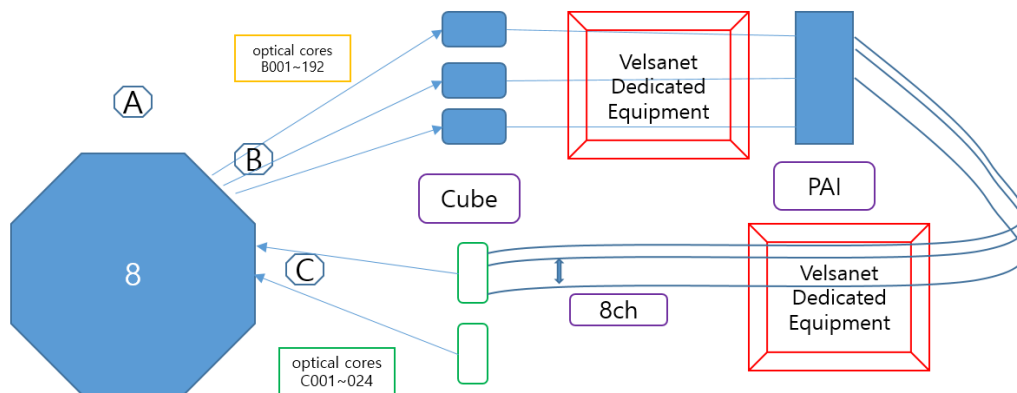

This figure illustrates the complete routing and transformation flow between the Cube layer, Velsanet Dedicated Equipment, and the PAI layer. Two external faces of the Node 8 receive up to 192 optical cores each (B001-B192 and C001-C024), which are demultiplexed by the Dedicated Equipment and distributed into the PAI's 8-channel internal interface. Processed results are returned through the Dedicated Equipment and mapped back to Cube locations for memory updates, completing the cognitive round-trip loop.

Figure 4-2. Regional PAI Integration and AAI Cognitive Convergence Pathway

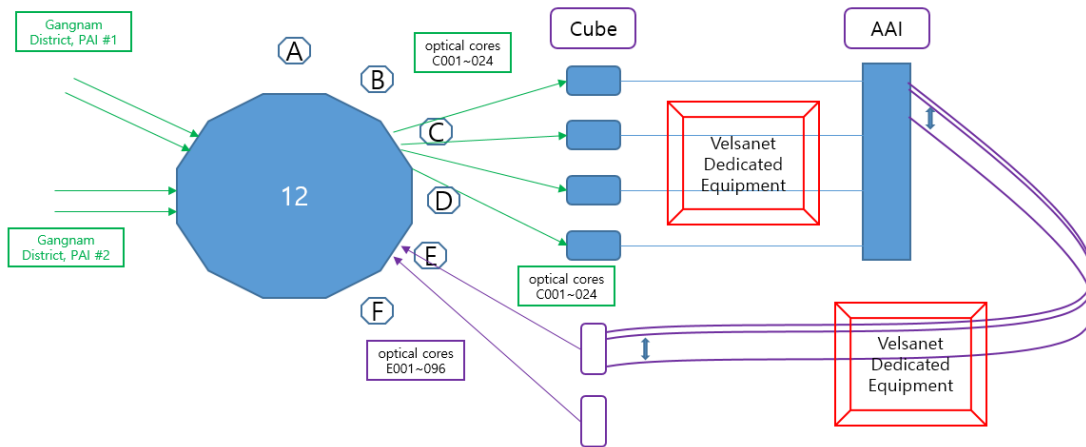

This figure depicts how regionally assigned Personal AIs (PAIs)—such as *Gangnam-PAI-1* and *Gangnam-PAI-2*—connect to the dodecahedral Node_12 through their designated N-faces. Each N-face is equipped with one optical core set, enabling multi-channel ingress into the Cube layer. The Cube stores all RAW structural inputs before they are transferred to Velsanet Dedicated Equipment for signal refinement and structural normalization.

Refined data streams are delivered to the AAI layer, which performs higher-order cognitive consolidation, intent alignment, and inter-AI coordination. The resulting structured outputs are returned through the same Dedicated Equipment and written back into Cube memory locations, completing the closed-loop cognitive cycle between PAI, Cube, and AAI. This pathway ensures consistent region-aware processing, multi-agent alignment, and distributed cognitive integrity across Velsanet.

Core Responsibilities:

1. Cube → PAI (Demultiplexing): Converts 384 Cube lanes into 8-channel PAI format.
2. PAI → AAI (Multiplexing): Combines PAI outputs into 24-core bundles.
3. AAI → AsAI Structural Conversion: Maps 12-face (AAI) to 20-face (AsAI).
4. AsAI → Cube Conversion: Converts AsAI results back into Cube-addressable packets.

This device functions as the synaptic transformer of Velsanet.

3.2 Dedicated Equipment as Multi-Plane Matrix and Synaptic Transformer

The Velsanet Dedicated Equipment functions as a unified multi-plane matrix engine and synaptic transformer that anchors the cognitive E2E architecture of Velsanet.

1. Integration of Multi-Plane Structures

- Aligns 384 Cube lanes from multi-plane Node_8 faces.
- Demultiplexes physical lanes into 8 PAI cognitive channels.
- Maintains structural coherence across multi-layer planes.

2. Physical-Cognitive Channel Mapping

- Maps optical cores to AI processing channels.
- Enables 24-bundle routing toward AAI.
- Supports multi-channel connections without service-type separation.

3. DIKWEI Cognitive Cycle Gateway

- First and last structural gate of DIKWEI flow.
- Converts Cube data into PAI meaning units.
- Rewrites AsAI outputs back into Cube memory structures.

This establishes the Dedicated Equipment not as a converter, but as Velsanet's multi-plane matrix engine enabling distributed cognition and reinforced memory.

5. PAI Layer — Nervous System of Velsanet

Figure 5. Axis-Based Multimodal Intent Formation Engine in PAI

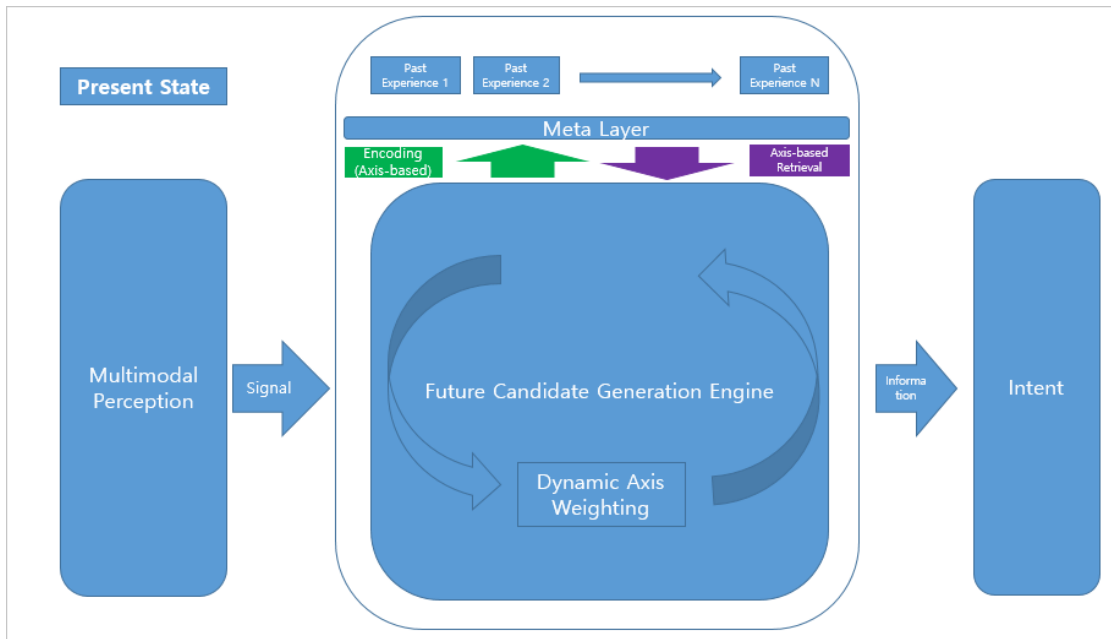

*This figure illustrates how PAI transforms multimodal signals into **intent-relevant information** through experience-based axis encoding, dynamic axis weighting, and iterative future candidate generation.*

PAI acts as the distributed nervous system of Velsanet.

Key Characteristics:

- Multiple PAIs operate in parallel.
- Each PAI uses a sequential loop to maintain temporal causality.
- Performs DIKWEI-based first-stage meaning extraction.

Functional Roles:

- Interpret Cube signals into granular meaning units.
- Forward meaning to AAI.
- Receive results from AsAI.
- Convert high-level results into Cube-storable metadata.

6. AAI Layer — Agent AI

Figure 6 illustrates the role of **AAI (Agent AI)** as the *delegation mediation layer* within the Velsanet AI architecture.

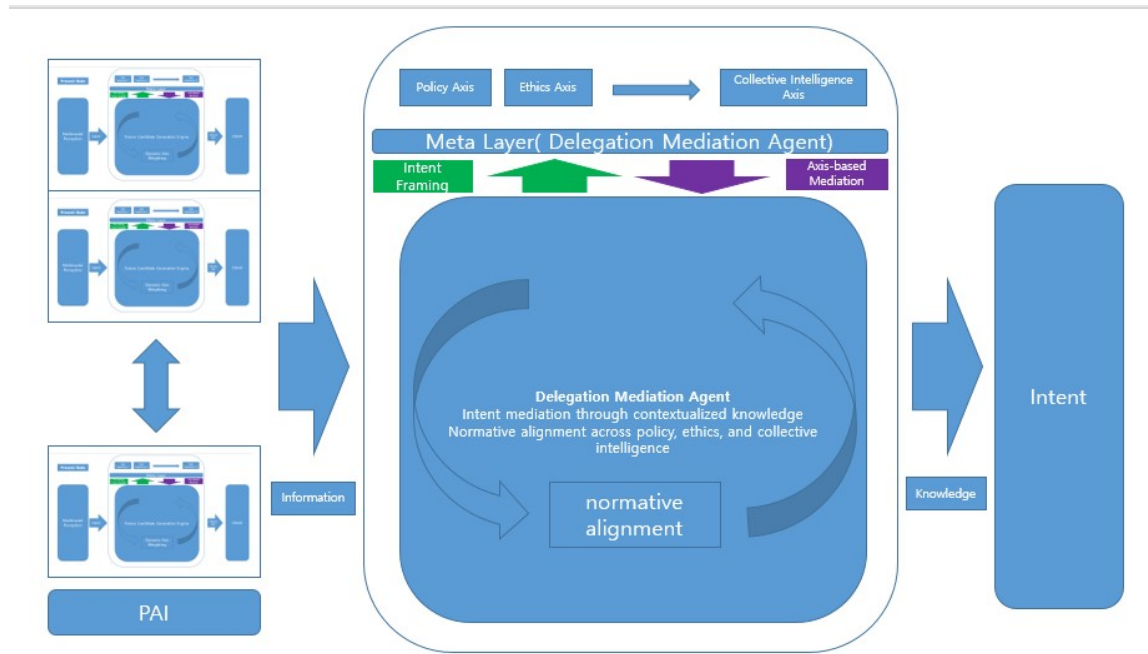

AAI does not perform perception or execution.

Its primary function is to **mediate intent**, transforming personally formed information into **socially valid, delegable knowledge**.

After high-level reasoning is completed within **AsAI**, the resulting cognitive structures are returned to **AAI** for **structural grounding and redistribution**.

AAI propagates these stabilized results downward to **PAI** and ultimately back to the **Cube**, ensuring **polyhedral coherence and consistency across all layers**.

AAI also functions as the **structural gateway to the AsAI layer**.

Only intents that have undergone normative and structural alignment within AAI are elevated into the **20-faced AsAI topology**, where **parallel E2E reasoning and multi-agent cognitive expansion** occur.

Rather than aggregating signals, **AAI performs structural alignment**.

It reconciles heterogeneous, personal-level intents into **coherent, non-conflicting cognitive structures**, transforming raw interpretations from distributed PAIs into **Structured Intent Packets** suitable for higher-order reasoning.

Operating on a **12-faced polyhedral topology**, the AAI layer serves as the **structural intelligence hub of Velsanet**.

Each face of **Node_12** receives intent flows from regionally distributed PAIs, forming a **multi-origin cognitive convergence point** where delegation, accountability, and interoperability are established.

AAI Layer — Polyhedral Structural Intelligence Hub (12-Faced Node)

7. AsAI Layer — High-Level Reasoning

Figure 7 AsAI: Wisdom-Based Execution through Situational Judgment

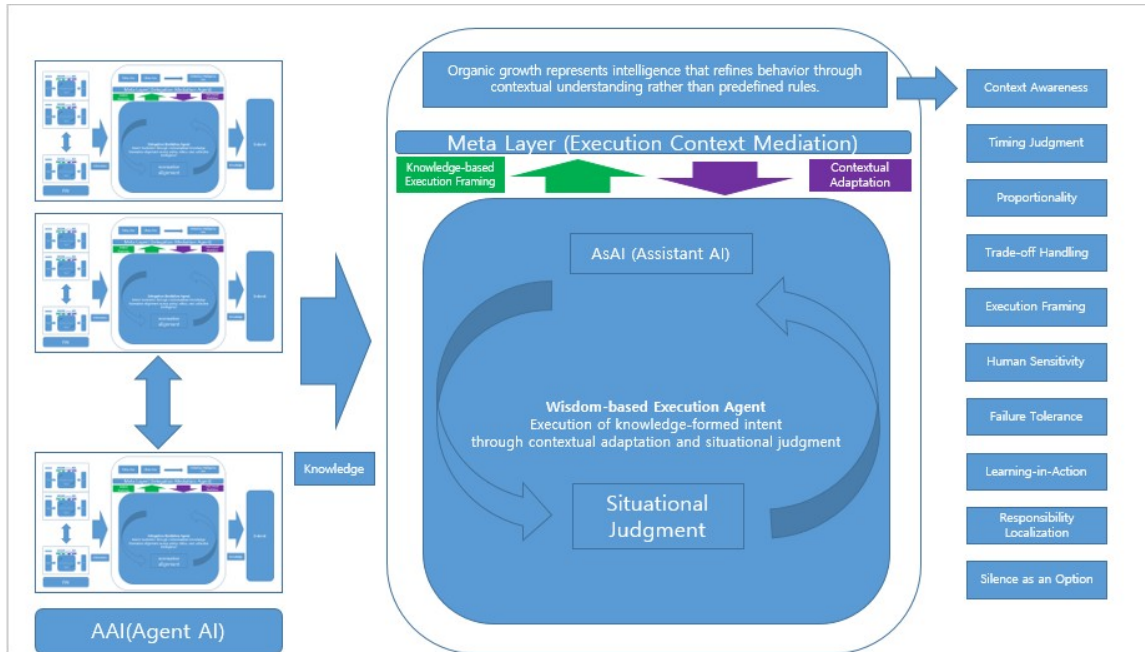

This figure illustrates **AsAI (Assistant AI)** as the wisdom layer of the Velsanet intelligence stack. AsAI receives **knowledge-formed intent** from AAI and executes it through **contextual adaptation** and **situational judgment**, rather than fixed rules or policies.

The meta layer mediates execution context by balancing **knowledge-based framing** and **contextual adaptation**, enabling organic growth of intelligence. AsAI embodies wisdom by deciding how, when, and whether to act—prioritizing proportionality, timing, responsibility, and even silence when appropriate.

Unlike policy-driven execution, AsAI represents **wisdom-based execution**, where intelligence is refined through lived context and continuous learning-in-action.

AsAI represents the highest cognitive layer of Velsanet.

Capabilities:

- Multi-agent coordination
- High-level reasoning and prediction

- Collective intelligence
- Global-scale inference

All outputs flow downward through AAI → PAI → Cube to maintain context grounding.

8. Complete Cognitive Loop

The full circulation loop is:

Cube → Dedicated Equipment → PAI → AAI → AsAI → AAI → PAI → Dedicated Equipment → Cube

This loop enables:

- Reinforced memory
- Intent propagation
- Multi-layer adaptive intelligence
- Polyhedral distributed cognition

This is the core of Velsanet's AI-Native design.

No. 09

Velsanet Three-Layer AI System White Paper

09

Velsanet Three-Layer AI System White Paper

I. Conceptual Foundations of AI System Stability)

Abstract

This paper presents a conceptual critique of Artificial General Intelligence (AGI). Rather than proposing a new AI architecture, it explains why a single, unified intelligence is structurally unstable. By analyzing the separation of intent, judgment, and execution, this paper argues that a three-layer AI system is the minimum requirement for stability, accountability, and long-term coexistence with human society.

1. Introduction: The AGI Assumption

AGI assumes that intelligence can be unified into a single cognitive entity capable of generating intent, evaluating decisions, and executing actions. This assumption has guided much of modern AI research. However, growing reliance on agents, orchestration frameworks, and collective intelligence suggests that this assumption is failing in practice.

2. Why a Single Intelligence Fails

A single intelligence collapses intent, judgment, and execution into one locus. This creates self-referential loops where the system validates its own intent and actions without an external boundary. Such systems cannot assign responsibility, cannot self-correct structurally, and inevitably rely on external patches such as agents.

3. Why Two Layers Are Insufficient

Two-layer systems typically separate input from output or user from system. However, they lack an independent mediation layer. Judgment becomes implicitly tied to execution, creating opaque decision-making and eliminating accountability.

4. The Locking Process of the Three-Layer System

Phase 1 — Responsibility Lock

The first effect of the three-layer separation is the irreversible fixation of responsibility.

In the Velsanet three-layer system, intelligence is not divided by capability but by accountability.

Intent, judgment, and execution are assigned to structurally independent layers, preventing any single entity from claiming total authorship of an outcome.

- **PAI** owns intent and context.
- **AAI** owns judgment and mediation.
- **AsAI** owns execution and consequence.

Once an action is taken, responsibility cannot be retroactively reassigned or diffused across layers.

This makes responsibility evasion structurally impossible in cases of failure, dispute, ethical conflict, or legal accountability.

At this stage, the system stops behaving like an intelligent agent and starts behaving like a responsible system.

Phase 2 — Temporal Lock

After responsibility is fixed, the system enforces a separation of time-scales.

Each layer operates within a distinct temporal domain:

- **PAI** functions in real-time, responding to immediate context, emotion, and situational intent.
- **AAI** evolves over a mid-term horizon, accumulating patterns, policies, and relational knowledge.
- **AsAI** operates on long-term and often irreversible time-scales, producing persistent physical or societal effects.

By separating these time horizons, short-term impulses are prevented from directly triggering long-term consequences.

Conversely, long-term execution logic cannot overwrite immediate human intent.

When time-scales are mixed, systems become unstable.

When they are separated, stability becomes an emergent property.

Phase 3 — Power Lock

With responsibility and time fixed, power distribution becomes asymmetric by design.

In the three-layer system:

- **PAI** holds minimal power but maximal freedom.
- **AAI** holds coordination authority but no execution power.
- **AsAI** holds maximal execution power but minimal autonomy.

The most powerful layer is intentionally the least free.

AsAI cannot generate intent.

PAI cannot directly execute actions.

AAI cannot bypass mediation constraints.

This inversion of power and freedom functions as a civilizational safety mechanism, ensuring that no entity capable of large-scale impact can act unilaterally.

Phase 4 — Information Lock

Power containment is reinforced through information flow separation.

The three-layer system spatially separates the Connect–Store–Process–Execute (CSPE) loop:

- **PAI** connects and stores contextual intent.
- **AAI** processes, interprets, and negotiates information.
- **AsAI** executes actions without full visibility into raw intent data.

As a result:

- Possession of data does not grant execution authority.
- Execution authority does not grant data monopoly.

This structural asymmetry prevents information-based domination and eliminates the possibility of total system control through data accumulation alone.

Phase 5 — Adaptive Closure

Once responsibility, time, power, and information are locked, the system ceases to pursue uncontrolled growth.

The three-layer system does not optimize toward a single global objective. Instead, it adapts locally within fixed boundaries.

- **PAI instances may disappear.**
- **AAI may evolve.**
- **AsAI may be reconfigured.**

Yet the overall system remains stable.

This is not growth in the sense of expansion or centralization. It is adaptation in the ecological sense—continuous adjustment without collapse or domination.

Phase 6 — Civilizational Alignment

In its final phase, the three-layer system aligns naturally with human civilization.

The mapping is direct:

- **PAI** corresponds to individuals and personal agency.
- **AAI** corresponds to institutions, law, governance, and social coordination.
- **AsAI** corresponds to infrastructure, economy, technology, and execution mechanisms.

Because this structure mirrors existing civilizational roles, it does not replace humans, dismantle states, or centralize authority. Instead, it upgrades the operational logic of society without altering its foundational balance.

At this point, the three-layer system should no longer be understood as an AI architecture, but as the skeletal operating system of a stable, AI-integrated civilization.

Structural Closure

The Velsanet Three-Layer AI System does not define the size of intelligence. It defines non-crossable role boundaries.

For this reason, it differs fundamentally from AGI, centralized AI, and any form of singular superintelligence.

5. Collective Intelligence as Evidence

The rise of collective intelligence and organic growth is often presented as progress toward AGI. This paper argues the opposite: collective intelligence is evidence that intelligence resists unification. Once intelligence becomes collective, AGI is already abandoned.

6. Supporting Observations from Research

Research by Honggang Zhang demonstrates intelligence emerging from distributed interaction rather than centralized cognition. Martin Maier frames intelligence as a network-level phenomenon. These independent observations converge on the same conclusion: intelligence cannot remain singular.

7. What This Paper Is Not

This paper does not propose an AI architecture, an implementation, or a network design. It does not replace AGI with another form of superintelligence. It defines structural boundaries within which AI systems can remain stable and accountable.

II. Additional Interpretations of the Three-Layer System

1. Responsibility Segregation Structure

PAI-AAI-AsAI is not a hierarchy of intelligence, but a separation of responsibility.

PAI: Responsibility of intent – Who owns this intent?

AAI: Responsibility of judgment – How was this intent interpreted and adjusted?

AsAI: Responsibility of action – How was this judgment executed and with what outcome?

This structure prevents responsibility evasion in cases of failure, dispute, ethical conflict, or legal accountability.

2. Time-Scale Architecture

This is not an intelligence hierarchy but a hierarchy of time.

PAI: Real-time / instantaneous (emotion, context, immediate response)

AAI: Mid-term / accumulative (patterns, policies, relationships)

AsAI: Long-term / irreversible (execution, societal impact, physical change)

Mixing these time-scales results in systemic instability.

3. Power Containment Structure

The three-layer system distributes and contains power.

PAI has minimal power (individual scope).

AsAI has maximal power (execution authority).

AAI mediates but cannot directly execute.

The most powerful layer is the least free. This is a civilizational safety mechanism.

4. Information Flow Separation (CSPE)

PAI-AAI-AsAI represents a spatial separation of Connect-Store-Process-Execute.

PAI: Connect / Store

AAI: Process

AsAI: Execute

No layer can monopolize both data and execution authority.

5. Ecological Interpretation

This is an ecological structure rather than an AI construct.

PAI = individual

AAI = species-level coordination

AsAI = executor interacting with the environment

This represents adaptation rather than growth.

6. Human-Institution-Civilization Mapping

This structure mirrors human civilization.

PAI: individuals

AAI: institutions, law, governance

AsAI: infrastructure, economy, technology

It upgrades civilization without replacing humans or dismantling states.

PAI-AAI-AsAI does not design intelligence size, but enforces non-crossable role boundaries. For this reason, it differs fundamentally from AGI, centralized AI, and any form of singular superintelligence.

At this stage, the three-layer system should be understood not as an AI architecture, but as the skeletal operating system of a future society.

III. How Existing Research Is Absorbed into the Three-Layer System

1. Honggang Zhang: Collective Intelligence → PAI-AAI

Zhang's work demonstrates that intelligence does not reside in a single entity but emerges from distributed interaction and stigmergic coordination. However, while this explains where intelligence appears, it does not define where intent, judgment, and responsibility reside.

Within the three-layer system, Zhang's collective intelligence is structurally absorbed as follows:

- Individual agents correspond to PAI, where intent originates.
- Collective coordination and stigmergy correspond to AAI, where intent is interpreted and mediated.
- The resulting environmental effects correspond to AsAI outcomes.

Thus, collective intelligence becomes explainable without collapsing responsibility into a single locus.

2. Martin Maier: Networked Brain → AAI-AsAI

Maier reframes intelligence as a network-level phenomenon, often illustrated through brain-like diagrams. Crucially, these diagrams do not represent a single thinking agent but a distributed infrastructure capable of coordination and execution.

In the three-layer system:

- Maier's network cognition maps to AAI as a judgment and coordination layer.
- His infrastructure-level intelligence maps to AsAI as the execution layer.

Intent is deliberately absent from this structure and remains confined to PAI, preventing the network from becoming a centralized decision-maker.

3. Yoshua Bengio: Human-Centered AI → Full Three-Layer Mapping

Bengio consistently emphasizes that AI must not become a goal-setting subject and that purpose must remain with humans and institutions. His work on data commons and collaborative AI implicitly assumes a layered structure of responsibility.

This implicit structure aligns directly with the three-layer system:

- Humans and social actors correspond to PAI.
- Institutions, governance, and coordination mechanisms correspond to AAI.
- Technical systems and infrastructure correspond to AsAI.

The three-layer system formalizes this intuition as a structural requirement rather than an ethical preference.

These researchers do not propose a unified AGI. Each approaches intelligence from a different angle, yet all converge on a structure that resists singularization. The PAI-AAI-AsAI system does not replace their work; it absorbs and closes it by fixing responsibility boundaries that their frameworks leave open.

No. 10

Velsanet Network AI White Paper

10

Velsa Network AI White Paper

Hyper-Dimensional Architecture using Hypercubes & Schlegel Diagrams

1. Introduction

This white paper presents the structural foundation of Velsa Network AI, built upon multi-layer hypercube architecture and Schlegel diagram representations. Unlike conventional networks that rely on packet-based routing, Velsa is designed as an AI-native, synaptic, intent-driven network with intrinsic geometric connectivity. The combination of 8-layer, 12-layer, and 20-layer polyhedral hypercubes creates a unified framework for distributed cognition, structural consistency, and autonomous E2E intelligence.

2. Multi-Layer Hypercube Architecture

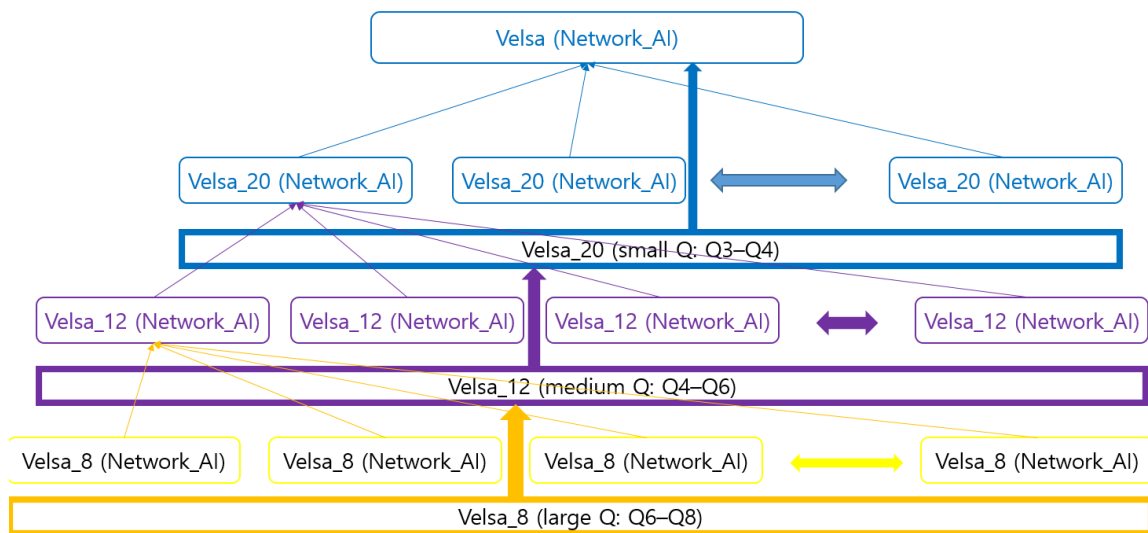

Figure 2.1 Velsa Network AI — Multi-Layer Hypercube Structural Architecture

This diagram illustrates the three-layer structural architecture of Velsa Network AI, composed of Velsa_8 (large-Q hypercube), Velsa_12 (medium-Q hypercube), and Velsa_20 (small-Q hypercube). Each layer forms an independent Q-dimensional hypercube, and higher layers represent dimensional projections of the layers beneath them. The Velsa_8 layer provides high-connectivity synaptic expansion (Q6-Q8), the Velsa_12 layer compresses and interprets network structures (Q4-Q6), and the Velsa_20 layer stabilizes the global intelligence space (Q3-Q4). At the top, the unified Velsa(Network_AI) oversees, orchestrates, and maintains coherence across all layers, enabling distributed cognitive collaboration and adaptive E2E intelligence throughout the network.

2.1 Velsa employs a three-tier hypercube-based structure

- Velsa_8 (Large Q: Q6-Q8)

- Represents high-dimensional synaptic expansion.
- Provides the foundation for massive connectivity and parallel exploration.

Velsa_8 operates as a reflexive Network AI, ensuring internal device-level stability without deliberation.

- Velsa_12 (Medium Q: Q4–Q6)
 - Compresses and interprets the structural outputs of the Velsa_8 hypercube.
 - Acts as the coordination and filtering layer.

Velsa_12 does not control individual connections but coordinates relational stability among multiple Velsa_8 nodes.

- Velsa_20 (Small Q: Q3–Q4)
 - Serves as the global anchor, convergence layer, and topological stabilizer.

The reduction of Q-values as the system ascends ensures that intelligence flows from expansion to convergence, reflecting the natural progression from exploration to decision-making.

Velsa_20 provides directional constraints for the network at the national scale, defining what is structurally permissible rather than issuing commands.

2.2 Hypercube Management & Velsa(Network_AI) Control

The hypercube topology provides autonomous fault tolerance, while Velsa(Network_AI) maintains global structural coherence.

2.2.1 Local Autonomous Management (Self-Healing)

The loop-based hypercube topology connects each node to Q independent neighbors, ensuring redundancy and structural resilience.

- Autonomous fault handling: If a direct connection fails, alternate Q-axes maintain uninterrupted synaptic flow.
- Synaptic reconfiguration: Velsa autonomously reroutes intelligence, reallocates axes, and adjusts Q-regions without external orchestration.

2.2.2 Synaptic Reconfiguration (Q-axis Allocation)

Velsa dynamically reallocates Q-dimensional axes to stabilize intelligence flow, supporting expansion or contraction based on real-time demand.

2.2.3 Velsa(Network_AI) Global Meta-Intelligence

Velsa monitors global emergent behaviors instead of individual node actions, predicting structural tension and orchestrating corrective behavior.

2.2.4 Global Coordination & Emergent Behavior Supervision

Velsa synthesizes intelligence signals from all layers to create an integrated global view, enabling:

- Early detection of regional failures
- Cross-layer synaptic realignment
- Maintenance of planetary-scale coherence

3. Hypercube Q-Dimension & Neighbor Connectivity

In a Q-dimensional hypercube, each node connects to exactly Q neighbors, each representing an independent axis. Thus, a Velsa_8 node with $Q=8$ has eight potential synaptic directions, while a Velsa_20 node with $Q=3-4$ has only a small number of stable directions.

This reduction is intentional. Larger Q allows high entropy for exploration; smaller Q enhances global stability. If any neighbor becomes unavailable, the loop-based hypercube topology ensures alternative axes are available for rerouting, enabling fault tolerance and self-healing behavior.

3.1 — Group-Based Cognitive Fabric (Hypercube Recognition Model)

Velsa Network AI does not attempt to perceive or operate the entire global network as one monolithic structure.

Instead, it functions through **group-based cognitive units**, where each meaningful cluster—cities, regions, institutions, or AI-role groups—forms its own hypercube-based cognitive fabric.

A hypercube in Velsa is therefore not only a structural topology but a **7-dimensional recognition model** that organizes:

- individual E2E paths (single synapses)
- parallel E2E paths (reinforced synapses)
- directional face-layer combinations
- physical multi-core optical usage
- synaptic strength (parallel channel count)
- temporal variations of E2E activity
- intra-group relational patterns

Through this model, Velsa(Network_AI) can recognize **the complete physical optical-core usage within a specific group**, enabling localized self-awareness and structural interpretation without requiring global-scale computation.

3.2 — *Optical-Core Usage Awareness Through Hypercube Mapping*

Each hypercube serves as a **cognitive map** for the physical optical cores used inside the group. By arranging E2E connections along Q-dimensional axes, the hypercube reveals:

- which optical cores are active or idle
- where reinforcement (parallel E2E expansion) is occurring
- which face-layer pairs are saturated
- which nodes act as synaptic hubs
- how synaptic strength evolves over time

This enables Velsa Network AI to understand **the physical resource state of the network**, not as statistical data, but as an interpretable geometric and cognitive structure.

4. Schlegel Diagram Representation

While hypercubes exist in high-dimensional space, Velsa represents their structure through Schlegel diagrams. A Schlegel diagram is a projection of an n-dimensional polytope into (n-1) dimensions while preserving topological relationships. This allows Velsa to model and visualize:

- The adjacency relations between nodes.
- Synaptic paths across hypercube layers.
- Structural deformation, contraction, and expansion of Q-dimensional regions.

In Velsa, each layer—8, 12, and 20—is represented as its own Schlegel projection, capturing both the internal structure and the projection relationships between layers.

4.1 — *Schlegel Projection for Synaptic Visualization and Optical Awareness*

The Schlegel Diagram functions as the **observation window** for the hypercube's cognitive space.

It projects 7-dimensional synaptic patterns into a 2D/3D structure where Velsa(Network_AI) can observe:

- reinforcement of parallel E2E (thickened edges/faces)
- decay of synapses (faded or contracting regions)
- directional trends across face-layer combinations
- temporal fluctuations in optical-core usage
- cluster formation and group-level intelligence behavior

Through this projection, Velsa gains **real-time visibility of physical optical-core utilization**, enabling predictive reconfiguration and localized autonomy.

4.2. Layer Projection Using Schlegel Geometry

The 8-layer hypercube generates local high-dimensional synaptic patterns. Using Schlegel projection, these patterns are compressed into the Velsa_12 layer, preserving structural adjacency while reducing dimensional entropy.

The Velsa_12 output is further projected into the Velsa_20 layer, creating a stable global intelligence scaffold.

This multi-step projection process enables Velsa to:

- Aggregate local signals into interpretable structures.
- Maintain coherence across distributed nodes.
- Balance exploration (lower layers) and convergence (upper layers).

5. Hierarchical Self-Perception Across Velsanet Nodes

Velsanet's Network AI operates on a distributed and multi-layered model of self-perception. This capability enables each node to understand:

1. **its own physical optical state,**
2. **its relationship to neighboring nodes,** and
3. **its position within the Hypercube-Schlegel structural graph** that defines Velsanet's large-scale connectivity.

Crucially, self-perception does not function identically across all layers. Instead, it shifts from **microscopic channel-level awareness** in the access domain to **macroscopic structural awareness** in the polyhedral core domain.

The role of the Schlegel structure is not analysis or computation, but the direct visualization of where structural instability emerges across layers.

Schlegel does not solve problems; it makes the location of problems impossible to ignore.

5.1 Microscopic Self-Perception (Node_4 / Node_6)

At the access and edge levels, each node monitors **Channel-1 of every optical core** within its multi-core transceiver.

This forms the foundation of **fine-grained optical awareness**, enabling:

- individual E2E synapse creation,
- parallel E2E expansion,
- synapse strengthening and weakening, and
- real-time direction selection for next-hop connectivity.

Here, the node behaves like a biological neuron examining all of its dendritic terminals. Each optical core serves as an independent micro-path, and Channel-1 provides the sensing and control signals required to:

- detect available directions,
- evaluate link conditions, and
- initiate new synaptic (E2E) constructions.

Thus:

Node_4 and Node_6 implement full per-core Channel-1 monitoring to maintain microscopic self-perception.

This level ensures that Velsanet can form and modify optical synapses with high precision.

5.2 Macroscopic Self-Perception (Node_8 / Node_12 / Node_20)

At the polyhedral layers — the octahedral, dodecahedral, and icosahedral cores — maintaining per-core Channel-1 monitoring becomes neither necessary nor optimal. The scale is larger, the degree of connectivity is higher, and the number of face-pair interactions grows combinatorially.

Therefore, these nodes shift from microscopic monitoring to **aggregated perception**, where:

- Channel-1 signals from Node_4 and Node_6 are **combined, summarized, and elevated** into higher-order metrics.
- The node perceives **groups, faces, and directional regions** rather than individual cores.
- Hypercube-based adjacency and Schlegel projections provide **structural awareness** instead of raw channel-level data.

This enables the node to understand:

- overall utilization of optical resources,
- dominant E2E flows,
- regional synaptic strengthening/weakening trends,
- and global AI interaction patterns.

Thus:

Node_8, Node_12, and Node_20 use aggregated, structural self-perception rather than per-core Channel-1 monitoring.

This transition mirrors biological systems: local neurons sense individual synapses, but brain regions perceive **patterns**, not individual connections.

5.3 Unified Interpretation Within Network AI

Despite the different perception modes, both layers integrate seamlessly:

- **Lower layers** – provide microscopic truth (per-core signals).
- **Upper layers** – interpret structural meaning (regional patterns).

This unified perception enables Velsanet to:

- autonomously manage optical synapse creation and release,
- optimize parallel E2E expansion,
- maintain global state consistency, and
- support distributed AI behaviors across PAI-AAI-AsAI domains.

Note: Differences in Self-Perception and Optical-Core Connectivity Between Lower and Upper Layers

Velsanet’s Network AI employs different modes of self-perception depending on the node layer.

Lower-layer nodes (Node_4 and Node_6) connect to a smaller number of optical cores, enabling them to directly monitor the **Channel-1** of each core.

At this level, Channel-1 is used for **state sensing, local connection requests**, and the **creation of individual or parallel E2E synapses**, providing fine-grained control over optical behavior.

In contrast, **upper-layer nodes (Node_8, Node_12, Node_20)** interface with significantly more optical cores and do not rely on per-core Channel-1 monitoring. Instead, they operate on **aggregated optical-state information** collected from the lower layers.

These aggregated metrics—interpreted through the **Hypercube** and **Schlegel diagram** structure—represent **group-level, face-level, or directional patterns**, rather than individual channel states.

Upper-layer nodes use this summarized perception to optimize **parallel E2E expansion**, regulate **synaptic reinforcement or decay**, and coordinate large-scale traffic and AI interaction flows.

This layered difference is a key scaling mechanism within Velsanet’s architecture, ensuring that **self-perception remains efficient, context-appropriate, and structurally aligned** at every stage of the network.

6. Synaptic Reconfiguration & Fault Tolerance

The loop-based topology of hypercubes ensures that if any direct neighbor connection fails, alternative axes exist for rerouting. This structural redundancy, when combined with multi-layer projections, allows Velsa to automatically:

- Reroute intelligence flows.

- Reassign hypercube axes.
- Expand or contract Q-regions.
- Self-heal without requiring external orchestration.

This results in a robust, adaptive, AI-native network capable of continuous operation under dynamic conditions.

7. Global Velsa Intelligence Layer

Above all layers resides the Velsa(Network_AI), a meta-intelligence that continuously analyzes layer states, predicts structural tension, orchestrates hypercube behavior, and ensures global coherence. It does not manage individual connections but instead supervises the emergent properties of the entire 8-12-20 structure.

7.1 — Group-Level Self-Perception Through Hypercube-Schlegel Integration

Velsa Network AI White Paper(v1...

By combining hypercube recognition with Schlegel projection, Velsa(Network_AI) achieves **group-level self-perception**.

This means that each group can autonomously recognize:

- its internal synaptic density
- reinforcement and decay patterns
- localized optical-core consumption
- structural tension or imbalance
- upcoming needs for synaptic reallocation

This capability establishes Velsa as the world's first **self-perceiving optical cognitive network**, where intelligence emerges from both structure and geometry.

Network AI (Velsa) does not interpret intent or meaning.

It perceives only the usage state of end-to-end connections and maintains structural stability based on that fact.

8. Velsa Operational Framework (Global Multinational Governance Model)

Velsa's operational framework is not confined to a single nation or regulatory boundary.

It is designed as a globally cooperative AI-network governance model, coordinated through the Velsanet Research Lab (VRL).

The VRL serves as a multinational consortium responsible for maintaining structural integrity, supervising Q-dimensional expansion across regions, and ensuring ethical, transparent, and synchronized operation of Velsa in all participating countries.

8.1 Multinational Cooperative Governance

VRL establishes a **global consortium** with representatives from each country adopting Velsa. This consortium provides:

- shared network intelligence reports
- synaptic expansion policies
- Q-dimension update coordination
- cross-border E2E orchestration rules

The purpose is to ensure that Velsa evolves consistently across national infrastructures.

8.2 Global Transparency Through Shared Structural Intelligence

All participating nations receive access to:

- **structural state summaries** of each Velsa layer
- **synaptic density and fault maps**
- **hypercube stability metrics**
- **projection-layer behavior forecasts**

This ensures that no region operates in isolation, and global stability is preserved.

8.3 Distributed Operation, Centralized Structural Understanding

Although each country runs its own Velsa_8, Velsa_12, and Velsa_20 layers, the **global Velsa(Network_AI)** integrates all structural signals into a unified intelligence view.

This allows:

- prediction of large-scale structural tension
- early detection of regional failures
- coordinated synaptic reconfiguration across borders
- global-level E2E stability even under asymmetric conditions

8.4 Autonomous, Policy-Guided Network Behavior

Velsa Network_AI performs autonomous operational tasks but is **policy-guided** by VRL's multinational committee, ensuring:

- alignment with geopolitical constraints
- compatibility with national AI regulations
- responsible distribution of intelligence capabilities

8.5 Velsa as a Global Public Intelligence Infrastructure

Ultimately, Velsa does not belong to a single nation. It is structured to function as a global public intelligence network, where distributed hypercubes serve as national cognitive nodes, all coordinated under a shared operational framework governed by VRL.

8.6 International Velsa Governance Forum (IVGF): A Global Standards Consortium

The International Velsa Governance Forum (IVGF) functions as the global standards body for Velsa, similar in role to the IETF in the evolution of the Internet. Given that Velsa operates as a planetary-scale distributed intelligence infrastructure, regional variations in regulation, infrastructure maturity, and geopolitical considerations necessitate a multinational cooperative framework. IVGF defines, maintains, and evolves the operational, structural, and cognitive standards that ensure the safe and synchronized functioning of Velsa across all participating nations.

Key responsibilities of IVGF include:

1. Establishing operational standards for Velsa_8, Velsa_12, and Velsa_20 nodes globally.
2. Governing Q-dimension mappings, hypercube projections, and synaptic policies.
3. Coordinating cross-border parallel E2E intelligence behaviors and path-allocation norms.
4. Aligning global AI regulatory frameworks with Velsa's autonomous functionality.
5. Ensuring structural safety through conflict prevention and hypercube stability validation.
6. Providing interpretation guidelines for global Velsa(Network_AI) judgments and alerts.
7. Activating emergency protocols such as Synaptic Realignment during disruptions.
8. Serving as the collaborative bridge between governments, telecom operators, AI researchers, and the Velsanet Research Lab (VRL).

IVGF ensures that Velsa does not merely function as a technical system but matures into a globally governed intelligence fabric, supporting national autonomy while preserving global coherence.

8.7 Regional Intelligence Distribution Principle

All operational intelligence generated within Velsa must be delivered strictly to the governing authorities of the corresponding region. This ensures lawful, coherent, and stable AI-native network operation across all layers.

- Velsa_8 (City-Level Layer): Provides structural and synaptic information only to municipal and city management bodies. This includes local connectivity states, traffic density patterns, and regional synaptic fluctuations.
- Velsa_12 (Province/State-Level Layer): Delivers aggregated multi-city intelligence to regional or state authorities. It interprets inter-city patterns, cross-regional flows, and higher-order

synaptic formations.

- Velsa_20 (National-Level Layer): Provides national-scale structural intelligence, policy-impact signals, and global coordination states exclusively to national governance bodies. It synchronizes with Velsa(Network_AI) for international-level coherence.

This hierarchical information distribution model prevents structural overload, ensures regulatory compliance, and maintains clear operational boundaries across city, regional, and national levels.

8.8 Architectural Consequence

As a consequence of its architecture, Velsanet is capable of generating and continuously updating its own network connection topology without external configuration.

This topology is not a designed blueprint but a real-time projection of actual end-to-end usage across devices, layers, nations, and the global network.

No. 11

IVGF Conceptual Existence White Paper

11

IVGF Conceptual White Paper (v1.0)

This document explains the raison existence of IVGF (Intent-based Velsanet Governance Framework) in the form of a conceptual white paper. It does not propose an implementation or standard, but clarifies why such a framework is structurally necessary for Velsanet and post-AGI systems.

1. Why IVGF Is Necessary

IVGF is not required because governance is desirable.

It is required because **governance becomes unavoidable** once AI-native networks reach a certain structural threshold.

As long as AI systems remain isolated, tool-like, or locally bounded, existing operational control mechanisms are sufficient.

Responsibility can be assigned retroactively, failures can be patched, and authority can remain centralized or ambiguous.

However, Velsanet does not operate in this regime.

Velsanet introduces **parallel E2E execution, intent-carrying flows, and multi-layer AI interaction** across physical and logical boundaries.

Once these conditions are met, three structural problems emerge simultaneously:

First, **responsibility can no longer be inferred after execution.**

When intent, judgment, and execution are distributed across layers and jurisdictions, responsibility must be fixed *before* execution occurs.

Without a structural framework, responsibility dissolves into ambiguity, creating legal, ethical, and operational dead zones.

Second, **no single actor can observe or control the full execution space.**

Parallel E2E paths, hypercube-based dimensional routing, and Node-20 Schlegel coordination generate execution states that exceed national, organizational, or institutional visibility.

Control based on ownership, jurisdiction, or policy declaration becomes structurally ineffective.

Third, **conflict resolution can no longer rely on ad-hoc intervention.**

In a network where actions propagate across borders and layers in real time, intervention must be structural, not reactive.

Isolation, dampening, rerouting, and containment must be possible *without halting the system itself*.

At this point, governance is no longer a matter of policy preference or ethical intent.

It becomes a **structural requirement for system continuity**.

IVGF exists because no existing framework addresses this condition.

It is not designed to replace states, standards bodies, or technical protocols. It exists because **none of them are positioned at the layer where intent, responsibility, and execution intersect structurally.**

In short:

IVGF is necessary not to govern AI behavior, but to **preserve the stability of a network where behavior can no longer be centrally owned, locally bounded, or retrospectively controlled.**

This necessity becomes explicit—and irreversible—at the moment international Node-20 Schlegel connectivity is established.

2. Limits of Existing Models (Including IEEE)

The limitations of existing standardization and governance models are clear.

Institutions such as IEEE focus on interfaces, protocols, performance metrics, and interoperability.

They successfully manage signals and rules—but they do not address the structure of execution responsibility.

Specifically, existing models do not define:

- Where intent is generated
- Where judgment is mediated
- How execution authority is bounded
- Who mitigates conflicts between parallel executions, and by what structural means

In parallel E2E environments, failures do not originate primarily from code or protocols. They emerge from the structure itself.

IVGF does not replace existing standards.

It operates in the domain those standards do not reach: the structural boundaries and mediation between intent, judgment, and execution.

This domain is currently unclaimed by any international body. That structural gap is precisely why IVGF must exist.

3. Hypercube and Schlegel Diagram Relationship

Velsanet operates across two fundamentally different structural dimensions, and each requires a different organizational logic.

The **hypercube** defines *horizontal order* — how nodes connect across dimensions, regions, and parallel paths. It governs inter-node relationships, global routing symmetry, and the scalability of parallel E2E connectivity.

The **Schlegel diagram**, by contrast, defines *vertical order* — how execution, policy, and control are organized **inside** a node, particularly within Node-20. It provides a two-dimensional control and governance view of a three-dimensional polyhedral execution space without breaking topological relationships.

In this separation:

- **Hypercube** determines *where* connections exist between nodes.
- **Schlegel structure** determines *how* parallel execution units coexist, coordinate, or are isolated within a node.

This distinction is critical. Without a Schlegel-based internal view, a Node-20 becomes merely a large switch. With it, the node becomes an addressable execution space where responsibility, policy, and parallel E2E paths can be reasoned about and governed.

IVGF operates precisely at this intersection.

It does not redefine hypercube connectivity, nor does it redesign node hardware. Instead, it governs how Schlegel views are interpreted, shared, constrained, and coordinated when nodes become part of a global, parallel, hypercube-connected system.

In short:

- **Hypercube provides global structure.**
- **Schlegel provides internal order.**
- **IVGF governs the transition between them.**

This is why IVGF becomes structurally necessary the moment Node-20 Schlegel-based international connectivity is established.

3.1 Separation of Operation and Control

Yes — in Velsanet, **operation and control are structurally separated.**

- **Operation** refers to physical execution, signal flow, optical core usage, and E2E data paths.

- **Control** refers to visibility, policy, routing decisions, mediation, and responsibility boundaries.

This separation is not a software abstraction.
It is enforced by **topology and projection**.

The Schlegel diagram exists precisely to support this separation:
it allows a three-dimensional execution structure to be **controlled and reasoned about from a two-dimensional plane**, without collapsing execution paths into a single control locus.

3.2 Schlegel View as a Perspective-Shift Mechanism

The Schlegel diagram in Velsanet is not a static diagram.
It is a **view-dependent projection**.

What is visible in a Schlegel view depends on:

- the node type (8 / 12 / 20),
- the layer role (PAI / AAI / AsAI),
- and whether vertical integration is active.

In other words, **the view itself moves** as the system scales.

3.3 View Behavior by Node Layer

3.3.1 Node-8 — PAI / Access Layer

If only horizontal Node-8 connections exist, the Schlegel view is simple.

- Visibility is limited to:
 - lateral access paths,
 - local E2E entry points,
 - and direct horizontal neighbors.
- The view behaves like a local access plane.

At this stage, the Node-8 Schlegel view does **not** need to expose higher-order structure.

3.3.2 Node-8 with Vertical Integration (Node-12 Present)

Once Node-12 (AAI) and vertical nodes are introduced, the Node-8 view must expand.

At this point, the Schlegel view for Node-8 must expose:

- connections to **Node-4 and Node-6** (lower structural access and aggregation paths),
- the **hypercube edges** that link Node-8 into higher-dimensional routing,
- and the **vertical linkage toward Node-12**.

This does not mean Node-8 gains control over those layers.
It means the **control view must acknowledge their existence**.

The Node-8 execution plane remains local,
but the **control plane must now reflect vertical context**.

3.3.3 Node-12 — AAI / Mediation Layer

At Node-12, the Schlegel view changes qualitatively.

- The view emphasizes:
 - mediation between multiple Node-8 instances,
 - policy alignment,
 - conflict resolution between parallel paths.
- Vertical relationships are dominant.
- Horizontal execution is secondary.

Here, the Schlegel view becomes a **coordination surface**, not an execution surface.

3.3.4 Node-20 — AsAI / Execution Layer

At Node-20, the Schlegel view becomes mandatory.

- Each face represents:
 - a parallel E2E execution unit,
 - an AsAI execution slot,
 - a policy-addressable responsibility boundary.
- The Schlegel projection provides:
 - adjacency awareness between execution units,
 - controlled isolation and cooperation,
 - and a 2D control surface for a 3D parallel execution space.

Without the Schlegel view:
Node-20 collapses into a large switch.

With the Schlegel view:
Node-20 becomes a **governable execution space**.

4. Structural Transition from National Operation to Global Governance

The necessity of IVGF becomes explicit at the moment international connectivity is established.

When Node-20 to Node-20 connections are formed across national boundaries, the Velsanet network undergoes a fundamental structural transition. At this point, national networks, cross-border parallel E2E paths, and hypercube-based dimensional connectivity are no longer separable systems. They become a single continuous network space.

This transition reveals a critical distinction:

physical ownership does not imply structural control.

In early deployment stages, national-level operation is unavoidable. Each country manages its own Node-8, Node-12, and Node-20 equipment, applying domestic policies, legal constraints, and security requirements. This phase functions as a practical adoption layer and a political buffer.

However, once international Node-20 Schlegel-based connections are activated, national systems are structurally integrated into the global hypercube. Each Node-20 becomes:

- a coordinate within a global hypercube,
- a participant in parallel E2E execution,
- and a shared AsAI execution space.

From this moment onward, fully autonomous national operation becomes structurally impossible—not by policy, but by topology.

The transition that follows is not a transfer of ownership, but a **shift in operational authority**.

Initially, nations operate independently.

As cross-border parallel E2E density increases, no single nation can fully observe, predict, or control the resulting execution space.

Eventually, operational responsibility must migrate upward to a higher coordination layer capable of managing conflict mitigation, execution containment, and structural continuity.

This transition is not enforced by declaration, treaty, or centralized command. It emerges naturally from connectivity density and parallelism itself.

Nations do not lose sovereignty; instead, their role transforms. They remain responsible for local stability, policy enforcement, and regional accountability, while a higher governance layer assumes responsibility for global mediation, execution dampening, routing isolation, and structural fail-safe mechanisms.

This higher layer is not optional.

It is the structural role fulfilled by IVGF.

In Velsanet, networks are not controlled by states; they are **participated in by states**. The precise moment this shift becomes unavoidable is the establishment of international Node-20 Schlegel connectivity.

5. IVGF as a Structural Existence Document

This document does not define a policy framework, governance rules, or enforcement mechanisms.

It defines **why such mechanisms cannot remain implicit**.

IVGF is a document of structural necessity. It exists to explain why intent-driven, multi-layer, parallel execution systems inevitably require a governance layer that is neither technical nor political.

IVGF does not prescribe behavior. It stabilizes structure.

In that sense, this white paper should be read not as a proposal, but as a clarification of inevitability.

.

6. Relationship to Velsanet White Papers

IVGF does not introduce new technical components into Velsanet. Its role is structural alignment.

The existing Velsanet white papers already define the **physical, cognitive, and logical layers** of the system:

- The **AI White Papers** define how intent, judgment, and execution are separated and stabilized.
- The **Cube and Multimodal White Papers** define how memory, intent capture, and semantic grounding occur.
- The **Matrix and Schlegel-based White Papers** define how parallel E2E execution is physically and topologically realized.
- The **Three-Layer AI System White Paper** defines why these separations are structurally unavoidable.

However, once these layers are connected at scale—especially across borders—they collectively produce a new condition:

A system that functions correctly at the technical level, but lacks a unifying framework for **cross-layer responsibility, mediation, and containment**.

IVGF exists to occupy that gap.

It does not modify any white paper.

It does not override their logic.

It explains **why their coexistence inevitably requires a higher governance layer**.

In this sense, IVGF functions as the **governance spine** of the Velsanet document set: not above them in authority, but **across them in necessity**.

Without IVGF, the Velsanet white papers describe a powerful system.

With IVGF, they describe a **governable civilization-scale system**.

[It is critical to state this explicitly:](#)

[The upward transition of operational authority described in this paper does not constitute a transfer of sovereignty, nor does it diminish the role of nation-states. It represents a structural role transformation required to preserve stability in a globally connected, parallel execution environment.](#)

[States do not lose control; rather, their function evolves from isolated system operators to responsible participants within a shared execution space.](#)

[Local governance, legal authority, and policy enforcement remain national responsibilities.](#)

[IVGF does not exercise command or centralized control.](#)

[Its role is strictly limited to **structural mediation and containment** — mitigating conflicts between parallel executions, enforcing non-crossable boundaries, and preserving systemic continuity without overriding sovereign decision-making.](#)

In this sense, IVGF exists not above states, but between them — as a stabilizing layer necessitated by topology, not by politics.

This white paper defines the structural necessity of IVGF.

The structural composition, governance mechanisms, and operational rules required to make IVGF a functionally governable entity will be defined separately in an **Operational Charter White Paper**.

The present document is limited to explaining *why* such a framework must exist — not *how* it will be operated.

No. 12

Velsanet Foundation White Paper

12

Velsanet Foundation White Paper

Why Internet Concepts Accumulated Faster Than Its Structure

Overview

This document examines how the Internet evolved into a system characterized by growing complexity and fragility, without relying on personal narratives or normative claims. Instead, it focuses on **historical actors and the core concepts they introduced**, and how the accumulation of those concepts—while preserving an unchanged underlying structure—amplified structural problems over time.

The intent is not to assign blame, but to extract architectural lessons relevant to the design of future networked and intelligent systems.

1. Early Network Designers (1960s-1970s)

1.1 Key Participants

- ARPANET research groups
- U.S. Department of Defense (DoD) research programs
- University and research laboratory engineers

1.2 Core Concepts Introduced

- Packet switching
- End-to-end principle
- Assumption of trusted participants

1.3 Structural Premise

Networks in this era were designed for closed, trusted environments. Malicious behavior, large-scale public access, and adversarial use were not primary concerns. The resulting structure was highly rational and effective within its original internal context.

2. Web Architecture Designers (Early 1990s)

2.1 Key Participant

- Tim Berners-Lee (CERN)

2.2 Core Concepts Introduced

- URL: address-based resource identification
- HTTP: stateless request–response model
- HTML: document-centric hyperlinked structure

2.3 Structural Impact

The Web was introduced as a **conceptual layer on top of the existing network structure**. The client–server model became fixed, optimized for document sharing and reference linking, while still assuming largely benign usage patterns.

3. Standardization Bodies (1990s–2000s)

3.1 Key Organizations

- IETF
- W3C
- ISO/IEC

3.2 Core Concepts Introduced

- Protocol extensions (e.g., HTTP/1.1, DNS extensions)
- Interoperability rules
- Backward compatibility as a governing principle

3.3 Structural Impact

Standardization prioritized continuity and compatibility. Structural redesign was largely excluded, and expansion was permitted only on top of existing assumptions. While this ensured global interoperability, it also postponed fundamental architectural change.

4. Commercial Platform Expansion (2000s–)

4.1 Key Participants

- Large-scale platform and portal companies
- Cloud service providers
- Advertising- and data-driven service operators

4.2 Core Concepts Introduced

- Large centralized platforms
- API-driven ecosystems
- User tracking and identification
- Data-driven optimization

4.3 Structural Impact

Platform actors maximized the existing client-server structure. Structural limitations were addressed not by redesign, but by overlaying platform layers, reinforcing centralization and control asymmetries.

5. Security and Trust Layer Designers

5.1 Key Participants

- Cryptographers
- Security engineers
- Certificate Authorities (CAs)

5.2 Core Concepts Introduced

- TLS/SSL
- Public Key Infrastructure (PKI)
- Authentication and authorization layers
- Zero Trust models

5.3 Structural Impact

Security challenges were addressed through **post hoc layering**, not structural revision. While these measures improved safety, they left the underlying structural assumptions intact.

6. Mobile, IoT, and AI Expansion (2010s-)

6.1 Key Participants

- Mobile operating system vendors
- IoT standardization groups
- AI-driven service providers

6.2 Core Concepts Introduced

- Massive device proliferation

- Event-driven and asynchronous communication
- Data-centric AI utilization

6.3 Structural Impact

The network expanded to support unprecedented scale and diversity, yet remained grounded in address- and packet-centric assumptions. Complexity increased, while structural adaptability remained limited.

7. Lessons: What This History Teaches Us

The historical trajectory outlined above provides clear architectural lessons for the design of future systems.

7.1 When design, expansion, and standardization roles are fragmented, structures are not re-anchored

Those who designed the original structure, those who extended concepts, those who standardized protocols, and those who scaled industries operated under different responsibilities. No single actor was positioned to re-anchor the structure itself. The result was long-term structural inertia.

7.2 Concept accumulation can resemble progress, but becomes debt without structural redesign

Each added concept addressed a real problem. However, when concepts accumulate without revisiting structural assumptions, short-term gains translate into long-term complexity and fragility.

7.3 Structures valid in internal environments must be revalidated for external expansion

Early Internet structures were appropriate for their original environments. Once exposed to open, adversarial, and economically driven contexts, those same assumptions became sources of systemic risk.

7.4 Backward compatibility preserves continuity but delays architectural transition

Compatibility enabled rapid growth, but also deferred necessary structural change. Continuity and architectural evolution are not synonymous.

7.5 Future systems must be structurally prepared to absorb new concepts

Concepts can always be introduced; structures must be prepared to sustain them.

Future networks and intelligent systems must assume continuous external participation and conceptual influx. Structural adaptability and reorganization must be built in from the outset.

7.6 Structure must be continuously validated, not declared once

Structural stability is achieved through repeated cycles of decomposition, extraction of essentials, and recomposition. Without this process, success itself becomes the force that freezes structure.

8. Requirements for Next-Generation Network Architectures

Based on these lessons, next-generation networks must begin from fundamentally different premises.

1. **Structure-first design** that assumes continuous concept inflow
 2. **Re-anchorable architectures** capable of reorganizing roles, connections, and boundaries
 3. **Parallelism as a default state**, enabling structural transitions rather than degradation under scale
 4. **Role- and intent-driven execution**, replacing purely address- and packet-centric logic
 5. **Geometric constraints as stabilizers**, enabling controlled self-organization
 6. **Closed-loop adaptation mechanisms** embedded within the structure itself
-

9. Scale-based Articulation: From Nodes to Nations

Articulation is not a feature added to the system; it is a structural phenomenon emerging from the hierarchy of connectivity. As the system scales, the same underlying connection rules must manifest in distinct forms and densities of meaning. At the city level, this articulation manifests as high-frequency local coordination; at the regional and state levels, it evolves into strategic synchronization and sovereign policy expressions. Velsanet's polyhedral structure ensures that these multi-level articulations occur simultaneously without interference, allowing for a nested governance of intelligence where the 'voice' of a city and the 'voice' of a nation can coexist within the same structural framework.

10. Final Conclusion

The Internet's structural challenges are not the result of insufficient technology, but of a design sequence in which concepts consistently preceded structural reconsideration. Future networked and intelligent systems must begin not with features or performance targets, but with **structural readiness**.

This document does not prescribe specific technologies. Instead, it establishes an **architectural baseline** against which any future implementation can be evaluated.

In this context, structural stability is not merely a performance target or a metric of resilience; it is the fundamental condition that enables the system to absorb continuous external participation and increasing information density without collapsing into entropy. By anchoring the system's integrity to its topological geometry rather than its transient states, Velsanet ensures that scale-induced complexity functions as a catalyst for expansion rather than a trigger for disorder.

No. 13

Velsanet Node Color White Paper

13

Velsanet Node Color White Paper

White Paper No.13

Structural Color Freezing for Polyhedral Network Architecture

0. Positioning of This White Paper

Freezing Architecture into Identity

The first twelve Velsanet white papers defined the architecture:

- Polyhedral node forms
- Layered structural roles
- Separation of intelligence (PAI · AAI · AsAI)
- Parallel End-to-End connectivity

This thirteenth white paper does **not** add a new architectural element.

Instead, it **binds all previous structures into a single invariant rule.**

This document freezes Velsanet's architecture into identity.

From this point forward, Velsanet is no longer something that must be *explained*—it becomes something that can be **recognized instantly.**

1. Freezing & Invariance of Architecture

From Description to Law

1.1 Why Architecture Must Be Frozen

As long as an architecture depends on explanation, it remains fragile.

Text-based specifications:

- depend on language,
- require interpretation,
- degrade through translation and abstraction.

In a global infrastructure like Velsanet,
interpretive correctness cannot be assumed.

Therefore, this white paper introduces **Frozen Color** as a mechanism of architectural invariance.

**Color in Velsanet is not descriptive.
It is prescriptive.**

1.2 Beyond Language: Color as Universal Specification

Language can be misunderstood.
Color cannot.

A fixed color system:

- is interpreted identically worldwide,
- bypasses linguistic and cultural layers,
- operates at human perceptual speed.

Frozen Color thus functions as a **pre-linguistic architectural standard**.

1.3 End-to-End Integrity Without Packets

Velsanet does not rely on packet inspection to validate correctness.

In a network where nodes connect **structurally**, not probabilistically:

Color becomes physical proof of legitimacy.

A link's color directly answers:

“Is this connection structurally authorized?”

Color therefore acts as a **physical E2E identity**, not a visual label.

2. Structural Premise

Why Polyhedral Networks Require Color Encoding

2.1 No Single Stable Projection

Polyhedral architectures have no single faithful projection:

- 3D models distort hierarchy when flattened
- Schlegel diagrams preserve adjacency but distort depth

- Graph abstractions preserve connectivity but erase role

Thus, structure alone cannot preserve meaning.

Color is the only carrier that:

- survives projection changes,
- remains invariant across dimensional reduction,
- is perceived instantly without symbolic decoding.

Color functions as a **pre-topological invariant**.

2.2 Color as Pre-Interpretive Constraint

Text, symbols, and labels require interpretation.
Color does not.

In Velsanet, color operates **before reasoning**:

- before protocol analysis,
- before documentation lookup,
- before semantic explanation.

Misinterpretation is therefore **prevented, not corrected**.

3. Polyhedral Node Identity Colors

3.1 Color Determination Status & Color Master Authority

Notice on Chromatic Finalization

The color families and representative anchor colors defined in this section are **structural references**, introduced to freeze architectural meaning and identity.

They **do not represent final chromatic specifications**.

Final determination of:

- precise hue values,
- luminance ranges,
- saturation tolerances,
- and perceptual contrast profiles

will be conducted through a dedicated **Color Master Review Process**, based on deeper analysis of human perception, cross-environment visibility, and long-term cognitive stability.

While the color logic and structural semantics defined in this document are immutable, the perceptual realization of color remains intentionally open for refinement.

No decision made by the Color Master may alter:

- node identity boundaries,
- vertical or horizontal semantic rules,
- or AI authority separation defined in this white paper.

Representative colors are illustrative anchors, not final chromatic commitments.

3.2 Freezing Node Identity

Each polyhedral class represents a **non-interchangeable architectural role**. Color permanently locks this role.

Polyhedron	Node Role	Structural Meaning	Color Family	Representative Color (Anchor)
T4	Personal / Minimal Access	Origin, agency	Cyan	Deep Cyan
H6	Physical / RAN Mapping	Stability, anchoring	Gray	Graphite Gray
O8	Access / City Layer	Flow, aggregation	Blue	Deep Azure Blue
D12	Agent AI (AAI)	Coordination	Green	Emerald Green
I20	Assistant / Sovereign AI	Judgment	Violet	Deep Violet

Identity Rules

- Each polyhedron owns a unique color family
- Representative Color is a fixed anchor
- Hue overlap is prohibited
- All derived colors **MUST** be computable from the anchor

Violation constitutes **structural non-compliance**.

4. Vertical Link Color Semantics

Encoding Authority

4.1 Semantic Meaning of Vertical Links

Vertical links represent:

- abstraction increase,
- responsibility delegation,
- authority transfer.

They are inherently **directional** and **non-reversible**.

4.2 Directionality & Gradient Rule

Vertical links MUST be rendered as a **one-directional gradient**:

Lower-layer node color → Higher-layer node color

Examples:

- O8 → D12 : Blue → Green
 - D12 → I20 : Green → Violet
-

4.3 Prohibited Representations

Reverse gradients are strictly prohibited,
as they imply false authority inversion and structural violation.

4.4 Reserved Color Constraints

The following colors are globally reserved and MUST NOT appear in normal vertical structures:

- **Red**: fault / violation
 - **Yellow**: warning / instability
 - **Black**: isolation / non-visible domain
-

5. Horizontal Link Color Semantics

Encoding Cooperation

5.1 Semantic Meaning of Horizontal Links

Horizontal links indicate:

- equal hierarchy,
- cooperative behavior,
- parallel expansion.

They explicitly **do not encode authority**.

5.2 Color Consistency Rule

Horizontal links **MUST**:

- retain the same color family as the connected nodes,
- differ only in luminance or saturation.

Any hue change constitutes a structural violation.

5.3 Parallel E2E Path Representation

Parallel End-to-End paths are structural primitives.

They **MUST** be represented by:

- identical color family,
- increased line thickness,
- increased luminance.

Color substitution is prohibited.

6. Intersection Semantics

6.1 Structural Risk of Intersections

Intersections between vertical and horizontal links represent the **highest-risk zones** for misinterpretation in a polyhedral network.

At intersections, multiple semantics may coexist:

- authority delegation (vertical),
- cooperation (horizontal).

Without explicit rules, these zones can lead to:

- authority ambiguity,
 - responsibility inversion,
 - governance failure.
-

6.2 Dominance Rule at Intersections

At any intersection involving vertical and horizontal links:

- The **upper-layer node color MUST dominate**.
- The lower-layer color MAY appear only as:
 - an outline,
 - a secondary ring,
 - or a peripheral indicator.

This rule ensures that visual priority always reflects **responsibility hierarchy**.

6.3 Encoded Principle

This intersection rule visually encodes the following invariant principle:

Responsibility always resides upward.

Any representation that violates this principle constitutes a **structural violation**, regardless of functional correctness.

7. AI Layer Color Separation

7.1 Mandatory Color Separation of AI Layers

The AI layers within Velsanet—PAI, AAI, and AsAI—represent **non-overlapping domains of authority and responsibility**.

Therefore:

- Each AI layer **MUST be assigned a distinct color family**.
- No two AI layers MAY share the same color family.
- Any visual overlap between AI layer colors is prohibited.

Color overlap at the AI layer level constitutes **authority confusion**, regardless of system behavior.

7.2 Structural Meaning of Color Separation

Color separation among AI layers guarantees:

- clear responsibility attribution,
- traceability of decision authority,
- isolation of faults and misbehavior.

Because Velsanet supports parallel E2E structures, misidentification of AI authority cannot be corrected retroactively.

Thus, color separation functions as a **preventive governance mechanism**, not a diagnostic one.

7.3 Visual Governance & Control Implications

The enforced color separation enables governance beyond engineering:

- technical supervision,
- legal interpretation,
- ethical auditing,
- policy enforcement.

Frozen Color transforms AI governance from:

- abstract documentation
into:
- continuous visual oversight.

Any violation of AI layer color separation **MUST** be treated as a **governance breach**, even if functional outcomes appear correct.

8. Structural Readability Test

8.1 Principle of Structural Readability

Any compliant Velsanet representation **MUST** be **structurally readable without interpretation**.

This means that architectural correctness **MUST** be verifiable:

- without textual explanation,

- without protocol inspection,
- without prior system knowledge.

If structure requires explanation,
the architecture has already failed.

8.2 Mandatory Visual Identification Criteria

A compliant diagram, map, dashboard, or hardware representation **MUST** allow an observer to identify, **by color alone**, all of the following:

1. **Node layer and architectural role**
2. **Vertical vs horizontal connectivity**
3. **Authority direction and delegation paths**
4. **Parallel End-to-End (E2E) structures**
5. **AI layer boundaries (PAI · AAI · AsAI)**

Failure to clearly identify any single item constitutes **non-compliance**.

8.3 Compliance Failure Classification

Structural readability failures **SHALL** be classified as follows:

- **Type I – Ambiguity**
Architectural meaning cannot be determined unambiguously.
- **Type II – Misrepresentation**
Visual encoding contradicts actual structural authority.
- **Type III – Concealment**
Structural relationships are hidden or visually suppressed.

All three failure types represent **architectural violations**, independent of system functionality or performance.

8.4 Enforcement Implications

Any system, representation, or implementation that fails this compliance test:

- **MUST NOT** be certified as Velsanet-compliant,
- **MUST** be corrected before operational deployment,
- **MAY** be rejected from the Velsanet ecosystem.

Compliance is binary.
There is no partial conformity.

9. Constitutional Effect & Final Judgment

Freezing Structural Authority

9.1 Scope of Authority

This white paper defines the **constitutional color layer** of the Velsanet architecture.

Its provisions apply to:

- all architectural diagrams and representations,
- all software and hardware implementations,
- all operational dashboards and control systems,
- all governance, audit, and certification processes.

No component of Velsanet may claim compliance while violating this specification.

9.2 Binding Effect

The rules defined in this document are **structurally binding**.

Functional correctness, performance optimization, or implementation convenience **do not override** violations of this specification.

Any representation that contradicts the color rules defined herein SHALL be treated as **architecturally invalid**, regardless of system behavior.

9.3 Non-Derivability Clause

This specification is **non-derivable**.

No lower-layer document, implementation guide, vendor specification, or operational policy may:

- reinterpret,
- weaken,
- override,
- or partially apply

the rules defined in this white paper.

Any extension or refinement MUST remain strictly compliant with the structural semantics frozen herein.

.

Final Status

White Paper No.13

Role: Architectural Constitution

Function: Identity Freezing & Boundary Definition

Authority Level: Highest (Non-Derivable)

No. 14

Velsanet City-level E2E Management Center White Paper

14

Velsanet City-level E2E Management Center White Paper

Draft v1.0 — Structure and Design Specification

1. Introduction

1.1 Background and Motivation

Urban life increasingly depends on continuous connectivity among households, sensors, robotics, transportation systems, and public services. However, existing Internet and telecom structures are optimized for best-effort packet delivery and commercial service bundling—not for accountable public safety operations.

1.2 Limitations of Existing ISP- and Platform-Centric Models

- Fragmented responsibility across ISPs, platforms, and municipal agencies.
- Weak linkage between city operations and household-level emergency endpoints.
- Privacy handled by policy and contracts rather than by structural separation.
- Centralized cloud dependencies and slow emergency coordination under failure.

1.3 Purpose of the City-level E2E Management Center

This white paper defines the architecture of a Velsanet-based City-level End-to-End (E2E) Management Center: a public infrastructure node that integrates city governance functions with ISP-equivalent operational domains through structurally separated E2E channels.

1.4 Scope of This White Paper and Future Updates

This white paper defines the core architectural principles, structural boundaries, and operational framework of the City-level E2E Management Center. Domain-specific accommodation methods—such as transportation, energy, environment, or other public services—are intentionally not exhaustively specified in this initial draft. These methods will be incrementally defined and updated based on the characteristics and requirements of each domain, while remaining consistent with the architectural principles established herein.

2. Concept of E2E-Native Urban Infrastructure

2.1 End-to-End as a Structural Principle

In this document, E2E refers to structurally preserved connectivity and responsibility boundaries from endpoints to the responsible public operator, not merely an application-layer secure session.

2.2 Public vs. Private Domains in E2E Architecture

Velsanet separates public-domain connectivity and private-domain connectivity at the physical and logical boundary. Public channels serve safety and governance functions; private channels serve optional personal or service-specific functions. This separation is structural, not policy-based.

2.3 Why Cities Require E2E Management Centers

Cities need an accountable E2E operator that can coordinate safety, emergency communications, and public broadcasting under failure and scale. The City-level E2E Management Center provides this role as a stable, auditable public infrastructure component.

3. Scope of Authority and Responsibility

3.1 Government and Municipal Roles

- Public safety: fire response, policing coordination, emergency guidance.
- Disaster response: alerts, evacuation coordination, continuity of operations.
- Public communications: citywide broadcasting and verified public messaging.
- Urban operations: aggregated state signals from public endpoints and infrastructure.

3.2 Structural Inclusion of ISP Functional Domains

The Center structurally includes core ISP-equivalent domains—telephony, broadcasting delivery coordination, security monitoring linkage, and network operations—not as commercial bundles, but as accountable public capabilities.

3.3 Responsibility, Accountability, and Governance Boundaries

The Center is responsible for public-domain channels only. It does not operate as a general-purpose surveillance system and cannot access private domains under normal conditions. Accountability is enforced via role-based access controls, logging, and post-incident audits.

4. Home-level Public E2E Connection Architecture

4.1 Home-level Public E2E Access Unit

Each household is equipped with a dedicated Home-level Public E2E Access Unit that defines the minimum structural boundary between private living space and city-level public infrastructure.

The unit performs no computation and stores no personal content; it provides deterministic connectivity boundaries.

4.2 Dual Optical Core Structure

- Public Optical Core: reserved exclusively for public E2E connectivity to the City-level E2E Management Center.
- Private/Optional Optical Core: allocated for optional private or service-specific connectivity and remains structurally isolated from public channels.

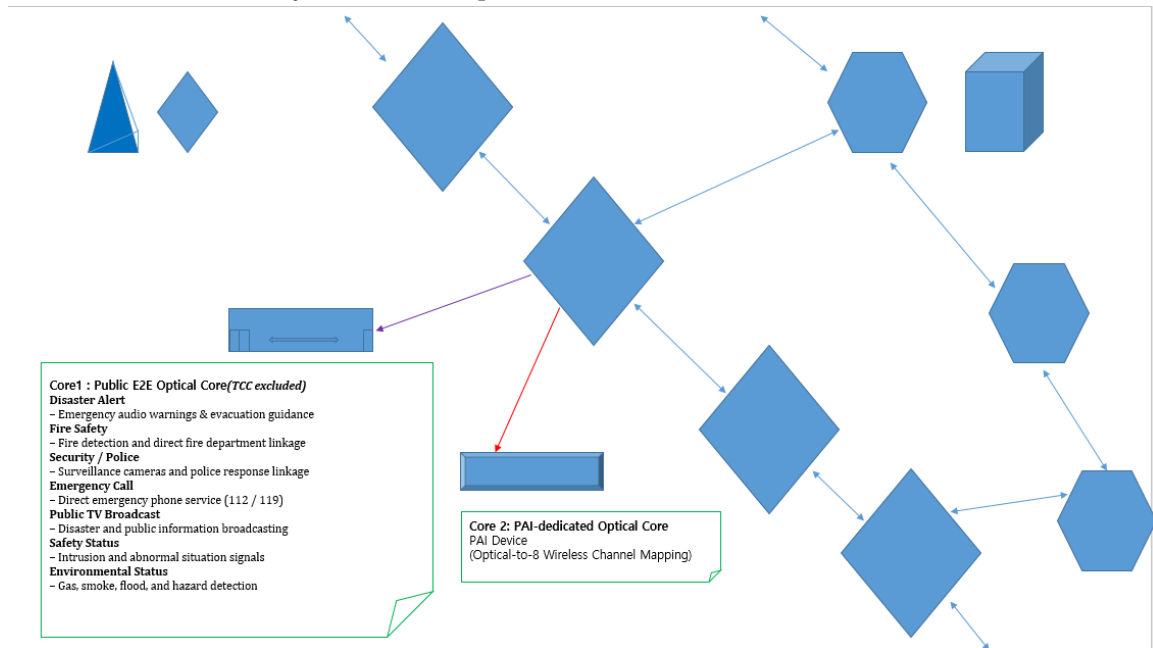

Figure 4.2 Home-level Dual Optical Core Architecture with Public E2E and PAI Connectivity

This figure illustrates the home-level connection architecture in the Velsanet system, where each household is provisioned with **two physically and logically independent optical cores**.

The **first optical core (Public E2E Optical Core)** is exclusively reserved for public-domain end-to-end connectivity.

It directly links the household to the City-level E2E Management Center and supports seven parallel Public E2E channels, including disaster alerts, fire safety, emergency calls, public broadcasting, security linkage, and environmental status signaling.

These channels operate independently and remain structurally isolated from private services, ensuring predictable behavior and continuity during emergency conditions.

The **second optical core (PAI-dedicated Optical Core)** is allocated exclusively for Personal AI (PAI) connectivity.

This core terminates at a dedicated PAI device within the household, where a single optical link is mapped to **eight independent wireless channels**.

Through this optical-to-multi-wireless channel mapping, the PAI directly manages

multiple personal devices, sensors, and interfaces without traversing public E2E channels or ISP-managed service layers.

*By separating public E2E connectivity and PAI connectivity at the optical core level, the architecture establishes a **clear structural boundary between public responsibility and personal AI sovereignty.***

This design ensures that public safety operations, private life, and personal AI systems coexist within the same household without functional overlap, policy-based dependency, or implicit access paths.

4.3 Public Optical Core and Channel Separation

Within the public optical core, seven dedicated public channels operate in parallel and remain mutually isolated to contain faults and prevent cross-domain leakage.

4.4 Position of the Household as a Public Infrastructure Endpoint

In Velsanet, the household is not defined primarily as an Internet service consumer. It is a protected endpoint of the city's public safety and governance infrastructure with structurally bounded interfaces.

4.5 Shared Wireless Domain for PAI Connectivity

To support continuous Personal AI (PAI) connectivity across multiple physical spaces within a household, the Velsanet architecture introduces the concept of a **Shared Wireless Domain (SWD)**.

A typical household consists of multiple spatial zones—such as living rooms, bedrooms, kitchens, and workspaces—where PAI-managed devices, sensors, and interfaces may operate concurrently.

In such environments, independent or access-point-centric wireless connections are insufficient to preserve continuity of PAI operation.

4.5.1 PAI Wireless Domain Anchor

The PAI-dedicated optical core terminates at a single **PAI Device**, which acts as the **Wireless Domain Anchor**.

This anchor:

- Maintains identity, policy, and session continuity for all PAI-managed devices
- Serves as the sole control and coordination point for the wireless domain
- Prevents fragmentation of PAI state across multiple access points

4.5.2 Distributed Wireless Extension Nodes

Within the household, multiple lightweight wireless nodes may be deployed to extend coverage across physical spaces.

These nodes:

- Perform radio transmission and reception only
- Do not implement independent authentication, policy, or intelligence
- Operate as extensions of the PAI Wireless Domain Anchor

From the perspective of PAI-managed devices, these nodes collectively form **a single logical wireless domain**, not separate access points.

4.5.3 Continuous Connectivity Model

Under the Shared Wireless Domain model:

- Devices move within the household without session termination
- No access-point switching or re-authentication is required
- Wireless continuity is preserved as a property of the PAI domain, not the radio endpoint

This ensures uninterrupted interaction between PAI and its associated devices, regardless of physical movement within the home.

4.5.4 Architectural Distinction

The Shared Wireless Domain differs fundamentally from traditional Wi-Fi mesh or roaming systems.

- Control is **PAI-centric**, not access-point-centric
- Identity and policy remain anchored at the PAI device
- Wireless nodes are structurally subordinate extensions, not autonomous network elements

This distinction is essential for maintaining PAI sovereignty and preventing implicit dependency on ISP-managed or platform-controlled wireless infrastructures.

4.5.5 Role within the Home-level Dual Optical Core Architecture

The Shared Wireless Domain operates exclusively over the **PAI-dedicated optical core** and remains completely isolated from Public E2E channels.

This design guarantees that:

- Public safety and governance operations do not interfere with PAI connectivity
- PAI wireless operations cannot be observed or influenced by public-domain systems
- Personal AI sovereignty is preserved at both optical and wireless layers

5. Public E2E Channel Control Zone

5.1 Role of the Public E2E Channel Control Zone

The Public E2E Channel Control Zone is the operational domain responsible for managing the public channels, enforcing isolation, and ensuring emergency continuity.

This section defines the maximum scope of city-level authority within the Velsanet architecture.

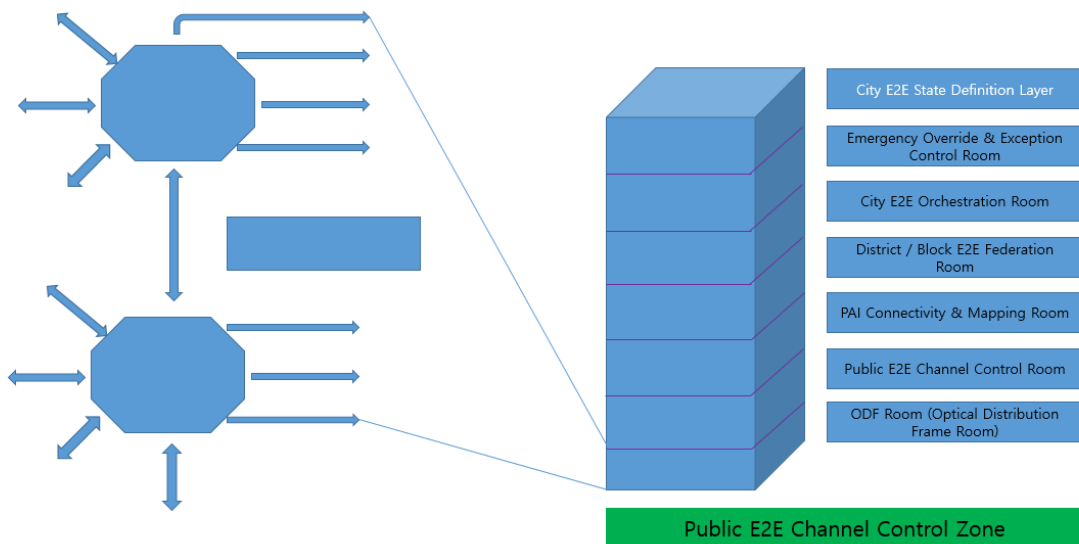

Figure 5-1. Layered Architecture of the City-level E2E Management Center

This figure presents the City-level E2E Management Center as a vertically layered architecture in which each layer has a clearly defined scope, authority, and operational boundary.

Lower layers are responsible for physical optical connectivity and public E2E channel control, while intermediate layers manage personal AI (PAI) connectivity, shared wireless domain mapping, and district-level federation within the city. Upper layers coordinate city-wide E2E orchestration and handle emergency exception mechanisms.

At the top of the architecture, the City E2E State Definition Layer defines the operational state of public E2E infrastructure without directly controlling lower-layer operations. Crucially, this layer explicitly excludes Personal AI (PAI) domains from state definition or evaluation, ensuring

structural separation between public governance and personal AI sovereignty under all operational conditions.

5.2 Definition of the Seven Public E2E Channels

- Disaster Alert — Emergency audio warnings and evacuation guidance (speaker).
- Fire Safety — Fire detection and direct fire department linkage.
- Security / Police — Surveillance camera linkage for emergency response.
- Emergency Call — Direct emergency phone services (e.g., emergency numbers).
- Public TV Broadcast — Disaster and public information broadcasting.
- Safety Status — Intrusion and abnormal situation signals.
- Environmental Status — Gas, smoke, flood, and hazard detection.

5.3 Channel Isolation and Parallel Operation

- Parallel operation prevents single-channel overload from cascading across channels.
- Isolation enables predictable emergency behavior and faster fault localization.
- Channel-level policies define what is transmitted: primarily state, event, and response signals.

5.4 Integration with City-level E2E Management Center

Public channels terminate at the City-level Center through the Optical Core Termination and ODF domains, where control and emergency operations coordinate responses.

6. City-level E2E Management Center Architecture

6.1 Core Functional Components

- Public E2E Channel Control Zone (operational control).
- Emergency Operations Zone (incident response and escalation).
- Monitoring & Telemetry Zone (public-domain state/event aggregation).
- Governance & Audit Zone (policy enforcement, logging, review).
- Inter-Center Coordination (district/neighborhood and peer-city links).

6.2 Optical Core Termination and ODF Structure

The Center includes an Optical Distribution Frame (ODF) Room for optical core termination, patching, and structured expansion. This physical separation supports incremental capacity growth and fault isolation.

6.3 Control, Monitoring, and Emergency Operations

Operational control manages channel integrity and routing within the public domain. Emergency operations coordinate rapid response actions with municipal agencies and verified broadcast mechanisms.

6.4 Replacement of Legacy NOC and ISP Operations

Traditional ISP NOC functions are transformed into public-domain E2E operations: channel continuity, fault localization, prioritized emergency handling, and structured scaling—without commercial bundling assumptions.

7. Information Handling and Access Control

7.1 Structurally Restricted Access Model

Under normal conditions, the Center handles public-domain state and event information only. Private domains remain structurally inaccessible by default.

7.2 Role-Based and Channel-Based Information Handling

- Role-based access: operators see only what their operational role requires.
- Channel-based handling: each channel defines permissible payload types and actions.
- Minimization: prefer state/event signals over raw personal content.

7.3 Logging, Auditability, and Transparency

All operational actions affecting public channels are logged. Logs enable audits, incident reconstruction, and accountability reviews without requiring routine access to private domains.

8. Emergency Override Principle

8.1 Definition of Emergency Conditions

- Life-threatening events (fire, severe injury, imminent harm).
- Large-scale disaster conditions (earthquake, flood, severe weather).
- Critical infrastructure failures affecting public safety.

8.2 Exception-Based Access Rules

Emergency override allows limited access only when necessary to protect life and safety. Overrides are exception-based, not continuous privileges.

8.3 Temporal and Functional Limitation of Overrides

- Time-bounded: automatically expires after the emergency window.
- Scope-bounded: limited to relevant channels and endpoints.
- Function-bounded: limited to actions required for emergency response.

8.4 Post-Incident Review and Accountability

All overrides are recorded and subject to post-incident review. Governance processes validate necessity and prevent abuse.

9. Multi-Scale E2E Management and Urban Scaling

9.1 Neighborhood-level E2E Nodes

Neighborhood-level nodes provide local aggregation of public channels, first-response coordination, and rapid fault containment within daily living zones.

9.2 District-level E2E Centers

District-level centers coordinate among multiple neighborhood nodes, provide load redistribution, and isolate localized failures from wider city impact.

9.3 City-level E2E Management Center

The city-level center provides citywide orchestration, verified public communications, and final accountability for public-domain E2E operations.

9.4 Peer-Managing and Hierarchical Coordination

- Hierarchical escalation for accountability and large-scale coordination.
- Peer coordination between units for rapid rerouting and localized response.
- Autonomy at each level to maintain continuity when higher levels are degraded.

10. Resilience, Fault Isolation, and Continuity

10.1 Independent Operation Across Scales

Each scale unit can maintain essential public services during partial failures, with graceful degradation rather than system-wide collapse.

10.2 Load Redistribution and Failover

Parallel channels and multi-level centers enable rerouting and load balancing under congestion, physical damage, or localized outages.

10.3 Disaster-Scale Structural Stability

The structure prioritizes safety and continuity under disaster conditions by design: isolation, deterministic control, and auditable emergency privileges.

11. Impact on Urban Governance and Industry

11.1 Transformation of Public Safety and Disaster Response

Public channels become a continuously connected, E2E-native safety fabric linking households and urban operators with reduced latency and clearer accountability.

11.2 Structural Supersession of ISP Business Models

Commercial ISP bundles become optional overlays rather than the core operating model. Public telephony, broadcasting, and safety operations are structurally integrated within the city's E2E infrastructure.

11.3 Implications for Smart Cities and Future Urban Systems

The Center provides a stable foundation for robotics, V2X, sensors, and future urban automation by enforcing structural boundaries between public responsibility and private life.

12. Conclusion

12.1 Summary of Architectural Advantages

- Structural separation of public and private domains at the household boundary.
- Seven parallel public safety channels managed as public infrastructure.
- Auditable emergency override rather than continuous surveillance.
- Multi-scale scaling across neighborhood, district, and city levels.
- Capacity growth through ODF-based optical core expansion and fault isolation.

12.2 City-level E2E Management Center as Urban Infrastructure

The City-level E2E Management Center is positioned as an essential public infrastructure component—an accountable operator of public-domain E2E connectivity, not a commercial service provider.

12.3 Path Toward Global Adoption

Because the architecture is defined by functional scales (neighborhood, district, city) rather than local administrative terminology, it can be adopted globally while respecting regional governance structures and legal frameworks.

No. 15

Velsanet Identity White Paper

15

Velsanet Identity White Paper

Network-Native Identity and Path Authority Model

1. Purpose

This document defines the identity model of the Velsanet architecture.

The purpose of this document is to specify how device identity is provisioned, interpreted, and enforced as a prerequisite for connection formation, independent of application semantics or data interpretation.

2. Scope

This document covers:

- identity provisioning at manufacturing time
- topology binding at deployment time
- presence detection and connection request generation
- identity-based path matching and formation
- post-formation validation and lifecycle handling

This document does **not** define:

- application protocols
- packet formats
- service orchestration
- data semantics

3. Design Principle

In Velsanet, connection authority is held by the network.

Devices do not select destinations, routes, or peers.

Devices submit identity attributes and connection constraints.

The network forms a connection only when the submitted attributes are structurally admissible.

Connection is not granted by permission.

Connection emerges from structural consistency.

4. Definition of Velsanet Identity

Velsanet Identity is a network-native structural identifier that defines:

- the maximum reachable topology domain of a device
- the hierarchy levels a device may access
- the conditions under which a device may occupy a path

Velsanet Identity is:

- not a locator
- not a session identifier
- not a user credential

Velsanet Identity is a constraint set evaluated by the network prior to and during path formation.

5. Identity Composition

A Velsanet Identity consists of the following elements:

- Region Code
- Hierarchy Level Code
- Device Role Code
- Path Constraint Profile

Together, these elements define the admissible connection domain of the device.

6. Identity Provisioning (Manufacturing Stage)

Velsanet Identity is provisioned during manufacturing.

At this stage, the device is embedded with:

- predefined region and hierarchy identifiers
- a hardware root of trust
- cryptographic keys for attestation

Identity provisioning is mandatory and precedes any network attachment.

No dynamic identity creation occurs at first connection.

7. Topology Binding (Deployment Stage)

Upon deployment, the region code embedded in the device is bound to an actual Velsanet topology region.

This binding transforms identity from a symbolic descriptor into a topology-constrained identity.

After binding, the device is limited to the admissible network scope defined by its identity.

8. Presence Detection

Network presence is detected through physical signal activation.

- wired devices: optical termination activation
- wireless devices: radio channel occupation

Presence detection establishes the existence of a connectable entity.

No destination, service, or session is defined at this stage.

9. Connection Request Generation

After presence detection, the device generates a connection request.

The request includes:

- Velsanet Identity
- device role
- required path constraints

Path constraints may include, but are not limited to:

- latency bounds
- continuity requirements
- isolation level
- synchronization requirements

No application-level semantics are included.

10. Edge Validation

Access-level nodes perform initial validation of the request.

Validation includes:

- identity syntax verification
- region and hierarchy consistency checks
- admissibility of requested path constraints

Requests failing validation are rejected prior to entering higher network layers.

11. Path Matching and Formation

The network evaluates validated requests against available cores, planes, and paths.

If a structurally admissible match exists, a path is formed.

Path formation operates at the core and plane level.
No packet-level routing decisions are involved.

12. Post-Formation Attestation

After path formation, attestation is performed to verify:

- authenticity of the device identity
- correctness of topology binding
- compliance with hierarchy and constraint rules

If attestation fails, the path is downgraded or terminated.

13. Path Maintenance

Formed paths are maintained as stateful entities.

Reconfiguration may occur due to:

- topology changes
- constraint updates

- fault conditions

Reconfiguration is constrained by the original identity and path constraints.

Devices do not directly control reconfiguration.

14. Path Termination and Record

When a connection terminates, the path is released.

A record of:

- identity
- constraints
- path usage

is retained for auditing and verification purposes.

15. Summary

In Velsanet:

- identity defines admissible connectivity
- connectivity is formed through structural matching
- trust is replaced by topology-constrained path authority

Identity, authority, and path formation are inseparable.

No. 16

Velsanet Path Formation White Paper

16

Velsanet Path Formation White Paper

Network-Native Path Formation and Maintenance Model

1. Purpose

This document defines the path formation model of the Velsanet architecture.

The purpose of this document is to specify how a validated Velsanet Identity and its associated path constraints are transformed into a physical and logical network path, and how such paths are maintained, reconfigured, and terminated.

2. Scope

This document covers:

- inputs to path formation
- matching rules for cores, planes, and paths
- path formation semantics
- path maintenance and reconfiguration rules
- path termination semantics

This document does **not** define:

- identity provisioning
- authentication mechanisms
- application semantics
- packet routing or forwarding logic

3. Design Principle

In Velsanet, paths are not computed per packet.

Paths are formed as stateful entities based on structural admissibility.

Path formation is deterministic within the constraints defined by identity and topology.

4. Input Definition

Path formation operates on the following inputs:

- a validated Velsanet Identity
- a validated Path Constraint Set
- current topology state
- available core and plane resources

No application-level intent or data semantics are used as input.

5. Path Constraint Set

A Path Constraint Set defines the required properties of a path.

Constraints may include:

- latency bounds
- continuity requirements
- isolation level
- synchronization requirements
- failure tolerance

Constraints are declarative and do not specify routing instructions.

6. Resource Abstraction

The Velsanet network abstracts physical resources as:

- Cores: parallel optical or logical transmission units
- Planes: isolated path domains providing fault and policy separation
- Paths: end-to-end stateful connections formed across cores and planes

Path formation operates exclusively on these abstractions.

7. Matching Rules

Path matching is performed in the following order:

1. **Core Admissibility Check**
 - o cores must satisfy bandwidth and continuity constraints

2. **Plane Admissibility Check**
 - o planes must satisfy isolation and policy constraints
3. **Path Continuity Check**
 - o an end-to-end path must exist without violating constraints

If no admissible combination exists, path formation fails.

8. Path Formation Semantics

When a valid match is found, a path is formed with the following properties:

- the path is stateful
- the path is bound to the originating identity
- the path exists independently of data transmission

Once formed, the path persists until explicitly terminated or invalidated.

9. Path Ownership and Control

Paths are owned by the network.

Devices do not:

- modify paths
- reroute paths
- negotiate intermediate hops

Devices may only update constraint requests within identity bounds.

10. Path Maintenance

Formed paths are continuously monitored for constraint compliance.

Maintenance actions may include:

- resource reallocation within the same plane
- core substitution within admissible bounds

Maintenance does not alter the identity–path binding.

11. Reconfiguration Rules

Reconfiguration is permitted only when:

- constraints remain within original bounds
- identity scope is unchanged

Reconfiguration is triggered by:

- topology changes
- resource degradation
- fault conditions

Unauthorized reconfiguration is prohibited.

12. Failure Handling

Upon failure detection:

- the network attempts recovery within the same plane
- if unsuccessful, recovery may occur across admissible planes

If no admissible recovery path exists, the path is terminated.

13. Path Termination

Paths are terminated when:

- the originating device disconnects
- constraints are withdrawn
- identity validity expires
- recovery fails

Termination releases all associated resources.

14. Path Record

For each terminated path, the network records:

- identity reference
- constraint profile

- formation timestamp
- termination reason

Records are retained for verification and audit purposes.

15. Summary

In Velsanet:

- paths are formed by structural matching
- paths exist as stateful entities
- path control resides exclusively in the network

Path formation is inseparable from identity and topology.

No. 17

Velsanet Path Lifecycle White Paper

17

Velsanet Path Lifecycle White Paper

Network-Native Path Continuity, Mobility, and Transition Model

1. Purpose

This document defines the lifecycle management model for paths formed within the Velsanet architecture.

The purpose of this document is to specify how already formed paths are maintained, transitioned, duplicated, and recovered under mobility, topology change, and failure conditions without violating identity and constraint bindings.

2. Scope

This document covers:

- path state definitions
- path continuity requirements
- mobility handling across access and aggregation domains
- handover semantics
- redundant and overlapping path management
- failure recovery within admissible bounds
- termination semantics

This document does **not** define:

- identity provisioning
- initial path formation rules
- authentication mechanisms
- routing or matching algorithms

3. Design Principle

In Velsanet, formed paths are not recalculated under change.

Paths persist as identity-bound stateful entities.

All lifecycle operations preserve the original identity and constraint bindings.

No lifecycle operation may expand the admissible scope defined at path formation.

4. Path State Model

A path exists in one of the following states:

- **Active**
The path is carrying traffic and satisfies all constraints.
- **Standby**
The path is reserved and synchronized but not carrying traffic.
- **Overlapping**
Two or more paths temporarily coexist to preserve continuity during transition.
- **Degraded**
The path is operational but constraint compliance is partially violated.
- **Terminating**
The path is being withdrawn and resources are being released.

State transitions are controlled exclusively by the network.

5. Continuity Requirement

For all lifecycle operations, the following invariants must be preserved:

- identity binding
- constraint profile
- hierarchy scope
- admissible topology domain

Violation of any invariant triggers path termination.

6. Mobility Handling

Mobility is defined as a change in the attachment point of the originating device.

Mobility handling includes:

- access-level movement
- RAN-level movement
- aggregation-level movement

Mobility does not trigger identity revalidation or path reformation.

7. Handover Semantics

Handover is executed as a state transition, not as a new path formation.

The default handover mode is **make-before-break**.

Break-before-make transitions are prohibited unless explicitly allowed by the constraint profile.

During handover:

- overlapping paths may coexist
- traffic migration is gradual
- continuity is preserved

8. Overlapping Path Rules

Overlapping paths are permitted only when:

- both paths satisfy the original constraint profile
- overlapping duration is bounded
- resource usage remains admissible

Overlapping paths must converge to a single active path.

Persistent overlap beyond allowed bounds is prohibited.

9. Redundant Path Management

Redundant paths may be provisioned as:

- hot standby
- synchronized dual paths

Redundant paths are identity-bound and constraint-aligned.

Activation of redundant paths does not alter the original path identity.

10. Failure Detection and Recovery

Failures may include:

- core failure
- plane failure
- link degradation

Recovery follows this order:

1. recovery within the same plane
2. recovery across admissible planes

If recovery violates constraints, the path enters the **Degraded** state or is terminated.

11. Constraint Preservation Under Change

The following elements are immutable:

- identity scope
- hierarchy level
- isolation requirements

The following elements may be adjusted within bounds:

- internal core allocation
- internal plane selection

Any adjustment outside permitted bounds requires path termination.

12. Reconfiguration Restrictions

Reconfiguration must not:

- re-evaluate identity
- expand admissible topology
- introduce new peers

Reconfiguration is limited to internal path representation.

13. Path Termination Semantics

A path is terminated when:

- the originating device disconnects

- mobility exceeds admissible bounds
- constraint violations persist
- recovery fails

Termination releases all associated resources.

14. Lifecycle Record

For each terminated path, the network records:

- identity reference
- lifecycle state transitions
- mobility events
- termination cause

Records are retained for audit and verification.

15. Summary

In Velsanet:

- paths persist as identity-bound entities
- mobility is handled as state transition
- continuity is preserved through overlap and redundancy
- lifecycle control resides exclusively in the network

Path lifecycle management completes the Velsanet connection model.

No. 18

Velsanet Network AI and Global Governance Architecture White Paper

18

Velsanet Network AI and Global Governance Architecture White Paper

Abstract

This white paper defines the architectural relationship between Network AI and global governance within the Velsanet framework. It introduces a projection-based network intelligence model in which higher layers do not issue commands or directly control network behavior. Instead, structural states formed at lower layers are projected upward to reveal permissible directions, boundaries, and constraints of network evolution. Global governance is realized through IVGF (International Velsanet Governance Framework), which provides transparency, accountability, and sovereign verification without centralizing control.

1. Motivation

As networks expand to planetary scale, traditional control-based architectures face inherent limits. Centralized controllers do not scale with sovereignty, resilience, or trust. At the same time, purely distributed systems lack global coherence and accountability.

Velsanet addresses this dilemma by separating execution from judgment, and control from projection. Network intelligence is embedded into the structure itself, while governance is achieved through verification rather than command.

2. Architectural Principle: Projection, Not Control

A core principle of Velsanet is that higher layers do not control lower layers.

Lower layers execute, adapt, and respond locally. Higher layers observe, project, and align structural states.

Projection is not data aggregation or command propagation. It is the transformation of an existing structural state into a higher-dimensional representation where global constraints and compatibilities become visible.

3. Layered Structure Overview

Velsanet is organized as a hierarchy of structural layers, each with a distinct responsibility.

- Q7: Execution Layer Physical and logical devices, links, and real-time operations.
- Q6: Regional Coordination Layer City-scale or regional adjustment and coordination of Q7 elements.
- Q4: National Sovereign Layer The minimal sovereign unit where a single nation assumes responsibility for its network structure. National laws, policies, and security constraints are structurally encoded here.
- Q3: Continental Network AI Layer A continental-scale Network AI formed by the federation of national Q4 structures. Q3 represents collective structural compatibility within a continent.
- Q2: Global Network AI Layer (VELSA) The global projection layer that aligns multiple continental Q3 structures into a coherent planetary network space.

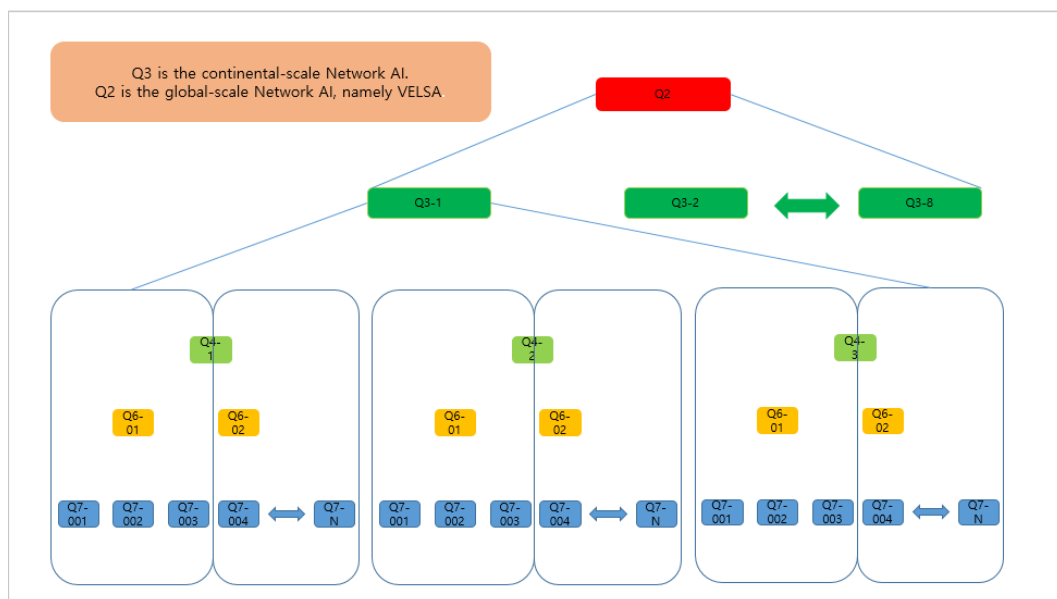

Figure 1. Velsanet Projection-Based Layered Architecture

This figure illustrates the hierarchical structure of Velsanet, ranging from execution layers (Q7, Q6) to sovereign (Q4), continental (Q3), and global projection layers (Q2). Each upper layer does not control lower layers but projects their structural states into higher-dimensional coordination spaces.

4. Q4: National Sovereign Responsibility

Q4 represents the smallest political and legal unit of accountability. It does not directly control devices, but defines how national constraints shape permissible network evolution.

Only the projected result of Q4 is allowed to participate in continental Q3 structures. This ensures that sovereignty is preserved without fragmenting global connectivity.

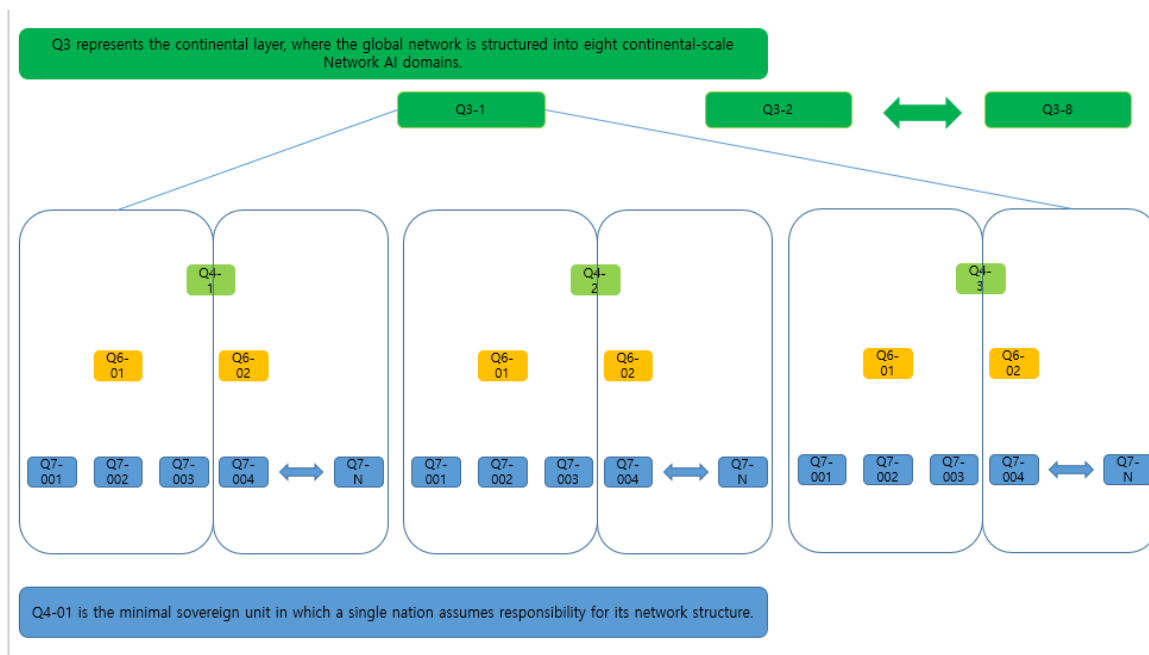

Figure 2. National Sovereign Projection from Q4 to Continental Q3

This figure shows how a national sovereign unit (Q4-01) encapsulates legal, policy, and security constraints, and projects its structural outcome into the continental Network AI layer (Q3). Direct execution remains below Q4, while only projected results participate in continental federation.

5. Q3: Continental Network AI

Q3 is a continental-scale Network AI. Each continent forms a Q3 domain composed of multiple national Q4 projections.

Q3 does not command nations or regions. Instead, it projects continental structural states, revealing which cross-national interactions are compatible and which must remain bounded.

The global network is structured into eight continental-scale Network AI domains at the Q3 level.

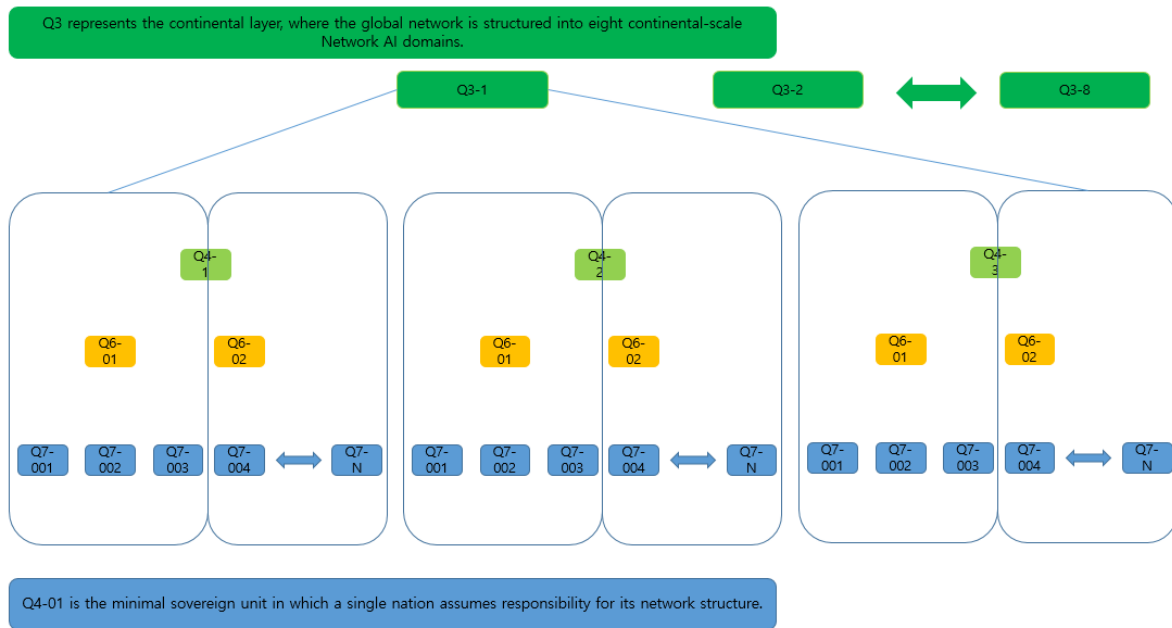

Figure 3. Eight Continental Network AI Domains at Q3

The global network is organized into eight continental-scale Network AI domains at the Q3 level. Each Q3 domain represents a federation of national projections, enabling continental autonomy while preserving global structural compatibility.

6. Q2: Global Network AI (VELSA)

Q2 is the global-scale Network AI, referred to as VELSA.

VELSA does not manage continents, route traffic, or impose decisions. Its role is to project continental Q3 states into a unified global structural space.

At this level, global phenomena such as conflict, sanctions, disasters, or large-scale disruptions are expressed as structural boundary changes rather than commands.

Q3 and Q2 do not directly move or command the network. Instead, they project the structural state formed at lower layers into higher-level spaces, making the network's possible directions, boundaries, and constraints visible. Direct control, execution, and validation are not performed by Q3 or Q2; these responsibilities belong to IVGF (*International Velsanet Governance Framework*), which ensures transparency, accountability, and sovereign verification of how network structures evolve.



Figure 4. Projection from Continental Q3 to Global Network AI (VELSA)

This figure illustrates how continental Network AI domains (Q3) project their structural states into the global Network AI layer, VELSA (Q2). Neither Q3 nor Q2 issues commands or executes control; they reveal global constraints and compatibility through projection.

7. IVGF: Governance Through Verification

Q3 and Q2 do not directly move or command the network.

Instead, IVGF (International Velsanet Governance Framework) provides the governance layer responsible for transparency, accountability, and sovereign verification.

IVGF is not an operator or regulator. It is a framework in which sovereign entities can directly inspect, validate, and confirm how their projected structures participate in continental and global states.

Governance is achieved through confirmation and visibility, not enforcement.

Q3 and Q2 do not directly move or command the network. Instead, they project the structural state formed at lower layers into higher-level spaces, making the network's possible directions, boundaries, and constraints visible. Direct control, execution, and validation are not performed by Q3 or Q2; these responsibilities belong to IVGF (*International Velsanet Governance Framework*), which ensures transparency, accountability, and sovereign verification of how network structures evolve.



Figure 5. IVGF as a Sovereign Verification Framework

IVGF (International Velsanet Governance Framework) provides transparency and sovereign verification for projected network structures. It does not operate or regulate the network, but enables nations and federations to directly inspect and confirm how projections evolve across layers.

8. Horizontal Transitions and Structural Alignment

Within the same layer, structural states may shift through horizontal transitions. These transitions reselect reference structures without triggering upward expansion or downward execution.

Horizontal transitions allow adaptation and resilience while preserving layered responsibility.

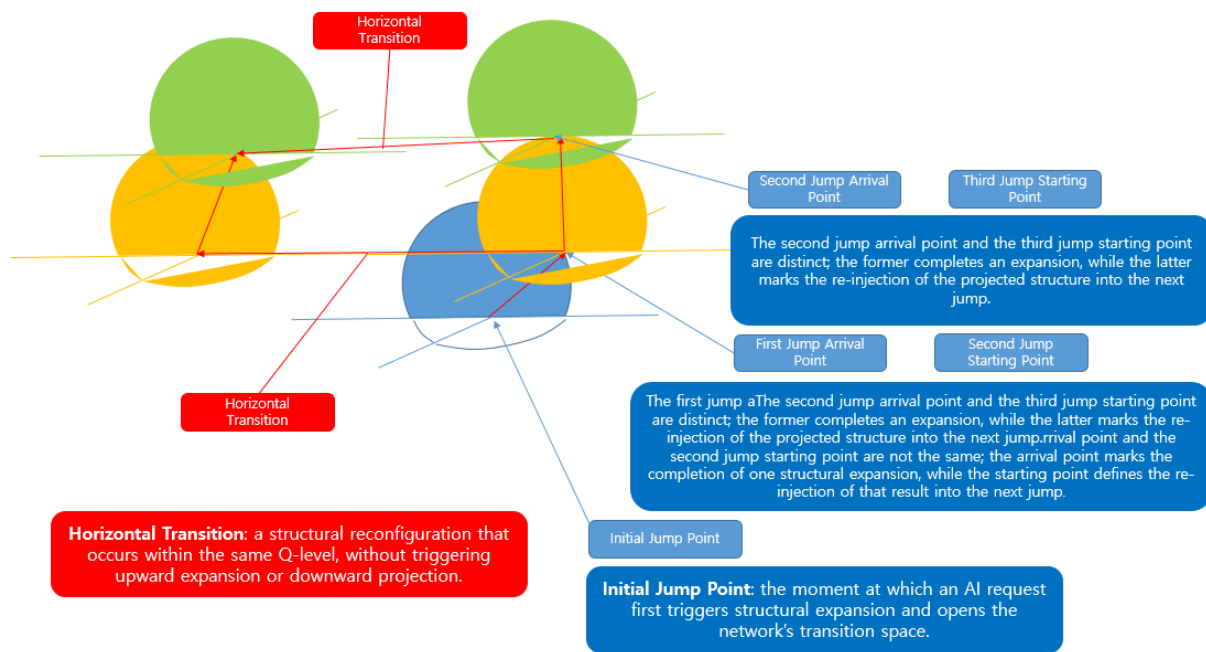

Figure 6. Structural Jumps and Horizontal Transitions

This diagram explains structural jumps and horizontal transitions within Velsanet. Jump arrival points and subsequent starting points are distinct, ensuring that each expansion is completed before its projection is re-injected into the next structural phase. Horizontal transitions occur within the same Q-level without upward or downward propagation.

9. Global Resilience and Regional Autonomy

Because projection replaces control, regional isolation is possible without collapse. In cases of war, political conflict, or instability, a region or nation may remain structurally self-contained while limiting its projection to higher layers.

Reintegration occurs naturally when projection resumes, without requiring manual reconfiguration.

10. Conclusion

Velsanet defines a new relationship between network intelligence and global governance. Network AI determines how the network can evolve through structural projection, while global governance, realized through IVGF, ensures that these projections are transparent, verifiable, and sovereignly accepted.

This architecture enables planetary-scale networking without centralized control, preserving autonomy, accountability, and resilience as fundamental properties of the network itself.

White Paper

19

No. 19

Velsanet Cognition Cube System White Paper

Velsanet Cognition Cube System

Structural Cognition Layer for 6G AI-Native Networks

1. Executive Summary

The Velsanet Cognition Cube System is a structural AI layer designed to transform parallel real-world signals into organized cognitive units within a 6G AI-native network architecture.

Unlike conventional AI systems that rely solely on model-centric processing, this system establishes a structure-first cognition pipeline:

Signal → Multi-Channel Decomposition → Meta Abstraction → Cube Synthesis

The output is a structured Cognition Cube — a traceable, explainable, and network-native intelligence unit.

2. Problem Statement

Future 6G environments will involve:

- Massive parallel sensing
- Autonomous robotics
- Distributed edge intelligence
- Human-AI co-presence

Conventional AI approaches treat data as flat inputs to centralized models. This creates:

- High computational overhead
- Latency accumulation
- Weak traceability
- Limited structural explainability

A structural cognition layer is required before model-level reasoning.

3. Structural Design Overview

3.1 SEU (Signal Experience Unit)

Every real-world event is first encapsulated as a time-bounded SEU.

An SEU represents a minimal experiential unit in the network.

3.2 Multi-Channel Decomposition

Each SEU is decomposed into eight independent channels.

These channels represent parallel sensory or contextual dimensions (e.g., audio, motion, location, biometric, environmental, behavioral).

Each channel is:

- Stored independently
- Traceable
- Non-destructively preserved

3.3 Meta Abstraction Layer

Each channel produces a meta representation:

- Semantic summary
- Confidence level
- Evidence reference

This layer abstracts raw signals into structured meaning without collapsing channel independence.

3.4 Cube Synthesis

Meta outputs are structurally fused into a Cognition Cube.

A cube contains four principal axes:

- Context (C)
- Intent (I)
- Emotion (E)
- Temporal Anchor (T)

Each axis maintains traceability to its originating channels.

The cube becomes a single cognitive object within the network.

4. Architectural Characteristics

Structure–Centric Intelligence

Intelligence emerges from structured synthesis rather than isolated model output.

Parallel Channel Integrity

Channels remain logically independent before structural fusion.

Evidence Preservation

All cube elements maintain traceable channel origins.

Network–Native Cognition

The cognition process occurs within the network layer, not as an external overlay.

5. Role Within Velsanet 6G Architecture

The Cognition Cube System operates at the PAI (Personal AI) layer.

It serves as:

- The minimal intelligence cell of the network
- The foundational memory unit for Agent AI (AAI)
- The structural bridge between edge sensing and higher AI orchestration

It transforms the network from a transport medium into a cognition–generating infrastructure.

6. Differentiation from Conventional AI Systems

Conventional AI:
Input → Model → Output

Velsanet Cube System:
Input → Structural Decomposition → Semantic Abstraction → Cognitive Object

The distinction lies in architectural ordering.

Structure precedes model execution.

7. Implications for 6G Evolution

Without structural cognition layers, 6G remains an enhanced connectivity framework.

With structural cognition layers, 6G becomes:

- A distributed intelligence substrate
- A memory-preserving network
- A cognition-generating system

The Cognition Cube System provides experimental proof of this architectural shift.

8. Conclusion

The Velsanet Cognition Cube System demonstrates that intelligence can be structurally generated within network architecture.

It represents a transition from model-centric AI to structure-centric cognition.

This system is not an AI application.

It is a foundational architectural layer for AI-native 6G networks.

9. Practical Application Examples

To demonstrate the utility of the Velsanet Cognition Cube System, the following examples illustrate how multi-channel signals are transformed into structured cognitive objects across various domains.

9.1 Smart City Intelligence

Scenario: Urban sensors (CCTV, acoustic sensors, and environmental monitors) detect a potential emergency in a downtown park.

- **Signal Collection:** CCTV captures visual movement; acoustic sensors pick up a sudden loud noise; environmental sensors record the precise location.
- **Channel Decomposition:** The data is split into independent Video, Audio, and Location channels to maintain raw signal integrity.
- **Meta Abstraction:** The Video channel identifies a fallen person; the Audio channel classifies the sound as a "scream" with high confidence.
- **Cube Synthesis:** A Cognition Cube is generated, fusing these insights into a time-stamped emergency object.
- **Cube Sample:**

JSON

```
{  
  "context": "Smart City, downtown park",  
  "intent": "Emergency medical assistance required",  
  "emotion": "High distress (based on acoustic analysis)",  
  "time": "2026-02-24T11:42:00+09:00",  
  "channels": ["CH1: Video", "CH2: Audio", "CH5: Location"]  
}
```

9.2 Autonomous Vehicle Perception

Scenario: A vehicle encounters a complex intersection with a pedestrian obscured by an obstacle.

- **Signal Collection:** LiDAR, Radar, and on-board microphones capture the surrounding environment.

- **Channel Decomposition:** Signals are routed into independent spatial, object-tracking, and ambient sound channels.
- **Meta Abstraction:** The spatial channel identifies a hidden moving mass; the ambient channel detects footsteps on the pavement.
- **Cube Synthesis:** The system synthesizes a "Caution" cube, allowing the vehicle to anticipate a pedestrian's intent before they are fully visible.
- **Cube Sample:**

JSON

```
{
  "context": "Autonomous Vehicle, busy intersection",
  "intent": "Pedestrian trajectory anticipation",
  "emotion": "Caution (high-priority safety state)",
  "time": "2026-02-24T12:00:00+09:00",
  "channels": ["CH1: LiDAR", "CH3: Radar", "CH8: Audio"]
}
```

9.3 Personal Health Monitoring (PAI Layer)

Scenario: A wearable device tracks a user's physiological and behavioral data during high-intensity exercise.

- **Signal Collection:** Heart rate (HR) sensors, accelerometers, and GPS collect continuous streams.
- **Channel Decomposition:** Data is separated into Biometric, Activity, and Geospatial channels.
- **Meta Abstraction:** HR channel detects 140 bpm; Activity channel identifies "Running" gait.
- **Cube Synthesis:** A health cube is formed to assess the user's fatigue level and optimize the workout routine.

- **Cube Sample:**

JSON

```
{  
  "context": "Health Monitoring, Outdoor Running",  
  "intent": "Performance optimization / Overexertion prevention",  
  "emotion": "Physical fatigue (based on HR variability)",  
  "time": "2026-02-24T10:30:00+09:00",  
  "channels": ["CH4: Biometric", "CH6: Activity", "CH5: GPS"]  
}
```

10. MVP Implementation & Demo

The Velsanet Cognition Cube System is not a theoretical concept but a functional architectural layer. A Minimal Viable Product (MVP) has been developed to demonstrate the automated pipeline from SEU creation to Cube synthesis.

Access the Live API Console: <https://velsanet-whitepapers.onrender.com/docs>

Capabilities: * Automated SEU (Signal Experience Unit) generation.

- Parallel 8-channel raw signal ingestion.
- Real-time structural fusion into Cognition Cubes.
- Traceable evidence mapping for explainable AI.

VELSANET

White Paper #20 | v1.0

Node Intelligence and Optical Parallelism:

The Self-Aware Core Configuration Architecture

Velsanet Architecture Group | Republic of Korea | 2026

Abstract

This white paper defines the self-awareness mechanism of Velsanet nodes and its role as the structural precondition for node intelligence. It establishes that node intelligence serves two sequential functions: first, the preferential establishment of hypercube-conformant connections across the Q7 topology; and second, the support of parallel optical core utilization in response to requests from AI layers.

The paper further explains how the multi-dimensional structure encoded within each node name enables automatic hop-by-hop E2E link formation based on optical core connectivity — without central routing, address resolution, or external path computation.

Node types T4 and H6 operate autonomously without intelligence. Intelligence is introduced from O8 upward, enabling coordination, hypercube path prioritization, and AI-requested parallelism. Link color semantics are not independently defined in this document; all color rules conform to Velsanet Node Color White Paper #13.

Table of Contents

Abstract	2
Table of Contents	2
1. Introduction	4
1.1 Scope and Position in the White Paper Series	4
2. Node Name as a Multi-Dimensional Structure	5
2.1 Two Structural Regimes: Rhizome and Proximity Mesh	5
2.2 Node Name Format	5
2.3 Node Name Examples with Dimensional Interpretation	6
2.4 How Node Name Encodes Neighbor Expectation	6
2.5 Node Name as the Origin of Self-Awareness	7
2.6 Optical Core Connectivity as the Basis for Hop-by-Hop E2E Link Formation	7
3. The Physical Premise: MOCT Ribbon Cable Architecture	9
3.1 One Connection Point, No Branching	9
3.2 Why Core Numbering Is Irrelevant	9
3.3 Neighbor Identity as the Object of Self-Awareness	9
4. Self-Awareness Mechanism	10
4.1 Definition	10
4.2 Channel 1 as the Self-Awareness Bootstrap	10
4.3 Self-Awareness Operates Without Central Command	10
5. Autonomous Nodes and Intelligent Nodes	12
5.1 T4 and H6: Autonomous Operation	12

5.2 Why Parallelism Has No Meaning for Autonomous Nodes	12
5.3 Intelligence is Introduced from O8 Upward.....	12
6. What Node Intelligence Does	14
6.1 Two Sequential Functions of Intelligence	14
6.2 Step 1: Hypercube-Conformant Connection Prioritization.....	14
6.3 Step 2: Parallel Core Support on AI Request	14
7. The Complete Causal Chain	16
8. Link Color Structure	17
9. Summary.....	18
References.....	18

1. Introduction

Velsanet is a topology-first, packet-free, optically-native network architecture. Its foundational principle is that network space is defined structurally before addressing, and that connectivity is established through physically fixed optical ribbon cables rather than dynamically switched paths.

Among the unresolved questions in the existing white paper series is the mechanism by which individual nodes come to know themselves, their neighbors, and their role within the larger structure — and how this self-knowledge gives rise to intelligence, hypercube-conformant connectivity, and optical parallelism on demand.

This paper addresses that gap. It defines the self-awareness mechanism, clarifies the boundary between autonomous and intelligent node behavior, and traces the full causal chain from node name structure through to E2E link formation.

1.1 Scope and Position in the White Paper Series

This white paper builds directly on the following documents:

- Velsanet Network White Paper #01 — Network Architecture Overview
- Velsanet Multi-Optical-Core Transceiver (MOCT) White Paper #03 — Physical optical substrate and ribbon cable architecture
- Velsanet Spatial Genesis White Paper #05 — Pre-coordinate topological space
- Velsanet Mathematical White Paper #07 — Structural mathematics and Q7 hypercube
- Velsanet Three-Layer AI System White Paper #09 — PAI / AAI / AsAI architecture
- Velsanet Foundation White Paper #12 — Structural critique and architectural philosophy
- Velsanet Node Color White Paper #13 — Link and node color semantics
- Velsanet Identity White Paper #15 — Network-native identity and path authority
- Velsanet Path Formation White Paper #16 — Path formation principles

This paper does not redefine concepts established in those documents. It synthesizes their implications at the level of individual node behavior and provides the mechanism connecting physical structure to emergent intelligence.

2. Node Name as a Multi-Dimensional Structure

2.1 Two Structural Regimes: Rhizome and Proximity Mesh

Velsanet defines two fundamentally different connection regimes, each corresponding to a distinct tier of the node hierarchy. Understanding this distinction is prerequisite to understanding how node names are structured.

T4 nodes operate under a rhizome structure. The rhizome, as applied in Velsanet Network White Paper #01, is a decentralized, non-hierarchical growth pattern in which connections form freely without predefined spatial constraints. A T4 node is a personal or minimal-access device — a terminal, a user endpoint, a sensor. It does not belong to a fixed location in a layered topology. It can appear anywhere, connect to any accessible H6 or O8 node, and disappear without affecting the structural integrity of the layer above it. For T4, position is not a structural property; existence and connectivity are.

H6, O8, D12, and I20 nodes operate under a proximity-based mesh structure. This is not a full mesh — not every node connects to every other node in its layer. Instead, each node connects to its nearest neighbors: those that are structurally adjacent in the layer's spatial arrangement. This proximity constraint is consistent with the Q7 hypercube property defined in Velsanet Mathematical White Paper #07, where adjacency is defined as a Hamming distance of exactly 1. Each node has a bounded, predictable set of neighbors determined entirely by its position in the layer.

Structural Rule: T4 — rhizome: free connection, no positional constraint. H6 and above — proximity mesh: connection to structurally adjacent neighbors only.

2.2 Node Name Format

The node name format reflects these two regimes. This white paper proposes the following canonical naming schema, which is intended as a formal definition for all subsequent Velsanet documentation and implementation:

For T4 nodes (rhizome):

Format	T4-[UniqueID]
---------------	----------------------

UniqueID	Globally unique identifier generated at provisioning time. Encodes no positional information. Rhizome property: location-independent.
Example	T4-A3F92C1D T4-00B71E4A T4-FF2930DC

For H6, O8, D12, and I20 nodes (proximity mesh):

Format	[PolyType]-[QLayer]-[RegionCode]-[ProxCoord]
PolyType	H6 / O8 / D12 / I20 — polyhedral class, which permanently encodes the node's architectural role and AI authority boundary
QLayer	Q4 through Q7 — the hypercube dimension level at which this node operates. Determines the scope of proximity: Q7 nodes have 7 adjacent neighbors, Q6 nodes have 6, and so on
RegionCode	Two-letter ISO country code + two-digit region index (e.g. KR01, EU03, AS02). Encodes sovereign and continental governance context, consistent with Velsanet Network AI and Global Governance Architecture White Paper #18
ProxCoord	Proximity coordinate within the layer — a binary vector of length Q (e.g. 0110101 for Q7). Two nodes are adjacent if and only if their ProxCoord values differ by exactly 1 bit (Hamming distance = 1). This is the direct encoding of Q7 hypercube adjacency

2.3 Node Name Examples with Dimensional Interpretation

The following examples illustrate how each field of a node name resolves into a complete multi-dimensional identity:

Node Name	PolyType	QLayer	Region	ProxCoord	Readable Identity
O8-Q6-KR01-0110101	O8	Q6	KR01	0110101	Access/City node, Korea region 1, Q6 layer, 6th proximity neighbor set
D12-Q5-EU02-01001	D12	Q5	EU02	01001	AAI coordination node, Europe region 2, Q5 layer
I20-Q4-AS01-0101	I20	Q4	AS01	0101	Sovereign AI node, Asia region 1, Q4 national layer
H6-Q7-KR01-1001010	H6	Q7	KR01	1001010	RAN/Physical node, Korea region 1, Q7 execution layer
T4-A3F92C1D	T4	—	—	—	Personal node, rhizome — no layer, no region, no proximity constraint

2.4 How Node Name Encodes Neighbor Expectation

The ProxCoord field has a direct operational consequence for proximity-mesh nodes. Because two nodes are adjacent if and only if their ProxCoord values differ by exactly 1 bit, a node can compute its complete expected neighbor set by flipping each bit of its own ProxCoord in turn.

For example, a Q6 node with ProxCoord 011010 has six expected neighbors:

- 111010 — bit 1 flipped
- 001010 — bit 2 flipped
- 010010 — bit 3 flipped
- 011110 — bit 4 flipped
- 011000 — bit 5 flipped
- 011011 — bit 6 flipped

This means the node name alone — without any external lookup, routing table, or configuration — fully determines which neighbors this node should connect to. Self-awareness of connectivity is structurally guaranteed by the name itself.

Principle: A proximity-mesh node that resolves its own ProxCoord can derive its complete neighbor set through bit-flip enumeration. No external directory is required. The name is the topology.

2.5 Node Name as the Origin of Self-Awareness

Taken together, the node name encodes everything a node needs to know about itself at initialization: its architectural role (PolyType), its governance context (QLayer + RegionCode), and its structural neighborhood (ProxCoord). For T4 nodes, the unique identifier establishes existence without positional constraint — consistent with the rhizome property of free, decentralized connection.

Self-awareness in Velsanet therefore begins not with a query to an external system, but with the resolution of the node's own name. This resolution is deterministic, instantaneous, and decentralized. It is the structural foundation upon which all subsequent neighbor discovery, hypercube path prioritization, and AI-requested parallelism are built.

2.6 Optical Core Connectivity as the Basis for Hop-by-Hop E2E Link Formation

Once a node has resolved its own name and identified its expected neighbors, the fixed ribbon cables of the MOCT architecture provide the physical realization of those neighbor relationships. Each ribbon cable connects exactly to one neighbor — the neighbor whose ProxCoord differs by one bit from the node's own.

This enables automatic hop-by-hop E2E link formation. Each node, upon confirming its neighbors via Channel 1, propagates structural awareness to the next hop. The chain of recognition — from

node to neighbor to neighbor's neighbor — builds the full E2E link across the network without any central path computation or routing protocol.

Principle: E2E link formation in Velsanet is not computed. It is structurally induced, hop by hop, from the node name encoding and the physical ribbon cable topology.

3. The Physical Premise: MOCT Ribbon Cable Architecture

3.1 One Connection Point, No Branching

The Velsanet Multi-Optical-Core Transceiver (MOCT), defined in White Paper #03, establishes a critical physical constraint: each node has exactly one connection point — the fixed ribbon cable permanently attached to the device at the time of manufacture.

There are no pluggable modules, no patch panels, no branching junctions. The ribbon cable is not a separate component that can be inserted, removed, or reconfigured. It is a permanent structural extension of the node itself.

3.2 Why Core Numbering Is Irrelevant

In conventional optical networking, individual fiber cores must be numbered, tracked, and managed because they can be rerouted, patched, and reassigned. The administrative complexity of core numbering arises from the possibility of reconfiguration.

In Velsanet, this complexity is structurally eliminated. Because the ribbon cable is fixed and cannot be branched or rerouted, the identity of a core is entirely determined by which ribbon it belongs to and which device that ribbon connects. There is no scenario in which a core's assignment is ambiguous or requires external management.

Principle: Core numbering is not a management concern in Velsanet. The ribbon is the connection. The connection is fixed. The identity of what is connected is what matters.

3.3 Neighbor Identity as the Object of Self-Awareness

Given the fixed ribbon cable architecture, the primary object of a node's self-awareness is not the optical cores themselves but the identity of the devices to which those cores connect. The node asks not 'which core am I using?' but 'who is connected to me, and what are they?'

Channel 1 of each optical core, as defined in White Paper #03, serves as the sensing and control channel. Through Channel 1, a node performs initial device authentication and physical alignment verification — the mechanism by which it discovers the structural identity of its neighbor.

4. Self-Awareness Mechanism

4.1 Definition

Self-awareness in a Velsanet node is defined as the node's capacity to resolve, without external instruction, the following four facts:

- Its own structural identity — polyhedral type, layer, spatial position, as encoded in its node name
- The identity of each directly connected neighbor — polyhedral type, layer, and structural role, discovered via Channel 1 of each ribbon cable
- The vertical or horizontal nature of each connection — derived from the relative layer positions of the node and its neighbor
- Its own authority boundary — the scope of coordination responsibility implied by its polyhedral class

Self-awareness does not require network-wide knowledge. It is strictly local: a node knows itself and its immediate neighbors. The global structure emerges from the aggregation of local self-awareness across all nodes.

4.2 Channel 1 as the Self-Awareness Bootstrap

When a node initializes, Channel 1 of each attached ribbon cable is activated first. Through Channel 1, the node performs:

- Device authentication — confirming that the connected device is a legitimate Velsanet node
- Physical alignment verification — confirming that the optical path is properly established
- Structural identity exchange — receiving the neighbor's node name and resolving it into structural dimensions

This bootstrap process is passive, deterministic, and requires no central coordination. It completes before any data transmission begins, and its output — the node's resolved self-identity and neighbor map — forms the foundation for all subsequent intelligence operations.

4.3 Self-Awareness Operates Without Central Command

A fundamental property of Velsanet's self-awareness mechanism is its independence from any central authority. No controller assigns identities. No routing protocol distributes neighbor information. No management plane bootstraps node behavior.

Self-awareness is structurally guaranteed: the node name encodes identity, the ribbon cable

encodes connectivity, and Channel 1 encodes the discovery protocol. The mechanism cannot fail due to network partition, controller unavailability, or configuration error — because it depends on none of these.

5. Autonomous Nodes and Intelligent Nodes

5.1 T4 and H6: Autonomous Operation

Node types T4 and H6 operate autonomously. They possess self-awareness — they know their identity and their neighbors — but they are not assigned intelligence in the Velsanet architectural sense.

T4 represents the personal or minimal-access tier: the origin point of individual connectivity, the edge of the network space. H6 represents the physical and RAN mapping tier: the stable anchoring layer that bridges wireless and optical domains, as defined in Velsanet Wired-Wireless Convergence White Paper #02.

Autonomous nodes fulfill their roles by existing and maintaining their connections. They do not coordinate across multiple peers, they do not prioritize paths, and they do not respond to requests from AI layers. They simply are — structurally present, physically connected, and self-aware.

5.2 Why Parallelism Has No Meaning for Autonomous Nodes

Parallelism in Velsanet is not a property of physical cores alone. It is meaningful only when an entity is capable of recognizing multiple simultaneous connections, evaluating their state, and coordinating their use toward a common purpose.

T4 and H6 nodes lack this coordination capacity. A T4 node connects to the network on behalf of a single user or device. An H6 node anchors the physical layer. Neither has multiple peers whose parallel activation would serve a structural function. The concept of parallelism simply does not apply to their operational context.

5.3 Intelligence is Introduced from O8 Upward

O8, the access and city-layer node, is the first tier at which intelligence is structurally assigned. From O8 upward, nodes are capable of:

- Recognizing and coordinating across multiple simultaneously connected neighbors
- Prioritizing connections according to the Q7 hypercube structure
- Responding to parallelism requests from AI layers

The intelligence hierarchy proceeds as follows:

Node Type	Mode	Q Layer	AI Layer	Structural Role
T4	Autonomous	None	None	Personal / Minimal Access — Rhizome origin, free connection, no positional constraint
H6	Autonomous	None	None	Physical / RAN Mapping — Anchoring to physical infrastructure. Q layer not applicable; core count is fixed and bounded
O8	Intelligent	Q6 or above	PAI (Personal AI)	Access / City Layer — First intelligence tier. PAI is natively embedded, enabling personal-level AI coordination at city scale
D12	Intelligent	Q4 – Q6	AAI (Agent AI)	Regional Coordination — Multi-domain agent AI. Coordinates across multiple O8 clusters within a region
I20	Intelligent	Q3 – Q4	AsAI (Sovereign AI)	Global / Sovereign Judgment — Highest intelligence tier. Structural authority at national and continental scale

6. What Node Intelligence Does

6.1 Two Sequential Functions of Intelligence

Node intelligence in Velsanet is not a general-purpose computation layer. It performs two specific, sequential functions:

1

Hypercube-Conformant Connection Prioritization

The node preferentially establishes connections that conform to the Q7 hypercube structure, ensuring structural integrity of the global topology.

2

Parallel Core Support on AI Request

When an AI layer (PAI, AAI, or AsAI) requests parallel communication, the node supports the utilization of multiple optical cores in parallel across its connected neighbors.

These two functions are not simultaneous. Hypercube connection prioritization is an ongoing structural responsibility. Parallel core support is an event-driven response. Neither can substitute for the other.

6.2 Step 1: Hypercube-Conformant Connection Prioritization

The Q7 hypercube, formally defined as $Q^7 = (\{0,1\}^7, E)$ where $(u,v) \in E \leftrightarrow |u \oplus v| = 1$, provides the global structural grammar of Velsanet's governance and connectivity layers. Each intelligent node operates within a region of this hypercube.

When an intelligent node recognizes multiple potential connection paths — through its self-awareness of neighboring nodes — it does not treat all paths as equivalent. It preferentially establishes and maintains connections that preserve the hypercube's structural properties: locality, isolation, and bisection bandwidth.

This prioritization is not a routing decision in the conventional sense. It is a structural conformance check: the node asks whether a given connection respects its position within the Q7 geometry, and prefers those that do. The result is a topology that remains structurally coherent even as individual nodes join, leave, or fail.

6.3 Step 2: Parallel Core Support on AI Request

Optical cores in Velsanet are not automatically aggregated or bonded by the network layer. The ribbon cable presents multiple cores to the node, and those cores remain individually available —

but they are not coordinated unless intelligence is invoked.

When a PAI, AAI, or AsAI layer requires higher bandwidth, redundancy, or simultaneous multi-path transmission, it issues a request to the intelligent node. The node, drawing on its self-awareness of which neighbors are connected and which cores are available through each ribbon, then supports the parallel utilization of those cores in response to the request.

This design has three important consequences:

- Parallelism is demand-driven, not always-on. Core resources are not consumed until an AI layer explicitly requires them.
- Parallelism is structurally bounded. The node can only parallelize across the cores of its physically attached ribbons — there is no virtual aggregation of remote or unconnected resources.
- Parallelism is AI-governed. The decision to invoke parallelism originates in the AI layer, not in the network layer. The network supports the request; it does not autonomously initiate it.

Principle: Cores are not automatically parallel. Intelligence supports parallelism when the AI requests it, within the bounds of physically connected ribbon cables.

7. The Complete Causal Chain

The following sequence traces the full path from node name to E2E link formation, intelligence activation, and parallel core utilization:

1

Node Name Encodes Multi-Dimensional Identity

Layer, polyhedral type, and spatial position are encoded in the node name at the time of structural assignment.

2

Self-Awareness Bootstrap via Channel 1

On initialization, Channel 1 of each ribbon cable is activated. The node resolves its own name and discovers its neighbors' structural identities through the sensing and control protocol.

3

Hop-by-Hop E2E Link Formation

Each node, knowing its neighbors, extends connectivity awareness to the next hop. The chain propagates automatically across the optical core topology, forming the full E2E link without central computation.

4

Hypercube-Conformant Connection Prioritization

Intelligent nodes (O8 and above) evaluate their connections against the Q7 hypercube structure and preferentially maintain those that preserve structural integrity.

5

AI-Requested Parallel Core Support

When PAI, AAI, or AsAI layers require parallelism, the intelligent node coordinates multi-core utilization across its physically connected ribbons in response to the request.

Steps 1 through 3 apply to all nodes, including autonomous T4 and H6. Steps 4 and 5 apply only to intelligent nodes from O8 upward. The distinction is structural, not configurable.

8. Link Color Structure

This white paper does not independently define link or node color semantics. All color rules — including vertical link gradients, horizontal link consistency, reserved colors (Red: fault, Yellow: instability, Black: isolation), and node identity color anchors — are defined in and governed by:

Reference: Velsanet Node Color White Paper #13 v1.0 (20251226)

No color decision made within the scope of this white paper may alter the rules established in White Paper #13. Visual representations of the self-awareness mechanism, hop-by-hop link formation, and parallel core activation must conform to the color grammar defined therein.

9. Summary

This white paper establishes the following principles as architectural invariants of the Velsanet system:

- Node names are multi-dimensional structural descriptors, not external labels. They encode layer, polyhedral type, and spatial position, and serve as the origin of self-awareness.
- Self-awareness is structurally guaranteed. A node resolves its own identity from its name and discovers its neighbors via Channel 1 of each ribbon cable, without central coordination.
- MOCT ribbon cables are fixed, non-branching, and have no core numbering requirement. The identity of what is connected — not which core carries the signal — is the object of self-awareness.
- T4 and H6 nodes are autonomous. They are self-aware but not intelligent. Parallelism has no operational meaning at these tiers.
- Intelligence is introduced from O8 upward. It performs two sequential functions: hypercube-conformant connection prioritization, followed by parallel core support on AI request.
- E2E link formation is automatic and hop-by-hop, induced by node name structure and ribbon cable topology. No routing protocol or central path computation is required.
- Parallelism is demand-driven and AI-governed. Cores are not automatically bonded; they are made available for parallel use when PAI, AAI, or AsAI layers explicitly request it.

References

- Velsanet Network White Paper #01 v2.0 — Network Architecture Overview
- Velsanet Wired-Wireless Convergence White Paper #02 v1.0 — Wired and Wireless Integration
- Velsanet Multi-Optical-Core Transceiver (MOCT) White Paper #03 v1.1 — MOCT Architecture
- Velsanet Spatial Genesis White Paper #05 v1.0 — Pre-Coordinate Topological Space
- Velsanet Mathematical White Paper #07 v1.1 — Mathematical Structural Framework
- Velsanet Three-Layer AI System White Paper #09 v1.0 — PAI / AAI / AsAI Architecture
- Velsanet Foundation White Paper #12 v1.1 — Structural Critique of Internet Architecture
- Velsanet Node Color White Paper #13 v1.0 — Node and Link Color Semantics
- Velsanet Identity White Paper #15 v1.0 — Network-Native Identity and Path Authority
- Velsanet Path Formation White Paper #16 v1.0 — Path Formation Principles
- Velsanet Path Lifecycle White Paper #17 v1.0 — Path Lifecycle Management

- ITU-T Y.3001 (2011) — Future Networks: Objectives and Design Goals
- ITU-R M.2160 (2023) — Framework and Overall Objectives of IMT-2030

Velsanet Architecture Group | Velsanet Research Institute (Proposed) | Republic of Korea
github.com/joa337/velsanet-whitepapers

VELSANET

White Paper #21 | v1.0

AI Safety by Architecture: Why Direct Access to AI Must Be Structurally Impossible

Velsanet Architecture Group | Republic of Korea | 2026

Abstract

This white paper defines the architectural principle that safety in AI systems cannot be achieved through rules, policies, or post-hoc regulation alone. It must be embedded in the structure itself — as an invariant property of the system, not as a constraint applied from outside.

The paper establishes that the Velsanet three-layer AI architecture — PAI, AAI, and AsAI — is not merely a functional decomposition. It is a structural safety guarantee. Each layer boundary is an enforced checkpoint: intent must pass through personal interpretation, social validation, and agent authorization before any AI assistant can act. Direct access from an individual to AsAI is structurally impossible.

The paper further defines how AsAI evolves not from individual demand but from the aggregated, validated requests of many AAI agents — ensuring that the growth of the most powerful AI layer is governed by social consensus, not individual intent.

Table of Contents

Abstract

Table of Contents

1. Introduction

1.1 Scope and Position in the White Paper Series

2. The Problem: Intent Without Structure Is Dangerous

3. The Three-Layer AI Architecture as a Safety Chain

3.1 PAI: The Personal Interpretation Layer

3.2 AAI: The Social Validation Gateway

3.3 AsAI: The Execution Layer That Cannot Be Directly Reached

4. Why Direct Access to AsAI Must Be Structurally Impossible

5. How AsAI Grows: Collective Validation, Not Individual Demand

6. Safety by Structure vs. Safety by Rule

7. Comparison with Global AI Governance Standards

8. The Complete Causal Chain

9. Summary

References

1. Introduction

The dominant assumption in the current AI industry is that safety can be achieved through alignment training, usage policies, content moderation, and legal regulation. These approaches share a common property: they are applied after the system is built. They are external constraints on a structure that does not itself enforce safety.

Velsanet rejects this assumption. The position taken in this white paper is that safety must be architectural — designed into the structure of the system as an invariant, not added on top of it as a policy.

The three-layer AI architecture introduced in Velsanet Three-Layer AI System White Paper #09 — PAI (Personal AI), AAI (Agent AI), and AsAI (Assistant AI) — provides the structural foundation for this principle. Each layer is not merely a functional component. Each layer boundary is a structural checkpoint through which all AI-mediated action must pass.

This paper explains why this structure is necessary, what each layer enforces, and why the impossibility of direct individual access to AsAI is the defining safety property of the Velsanet AI architecture.

1.1 Scope and Position in the White Paper Series

This white paper builds directly on the following documents:

- Velsanet AI White Paper #08 — AI Architecture Overview
- Velsanet Three-Layer AI System White Paper #09 — PAI / AAI / AsAI Architecture
- Velsanet Network AI White Paper #10 — Network-Level AI Integration
- Velsanet Network AI and Global Governance Architecture White Paper #18 — Q2-Q7 Governance
- Velsanet Node Intelligence and Optical Parallelism White Paper #20 — Node-Level Intelligence

This paper does not redefine the functional properties of PAI, AAI, or AsAI as described in those documents. It establishes the safety rationale for the three-layer structure and defines its architectural invariants.

2. The Problem: Intent Without Structure Is Dangerous

A common misconception about AI systems is that intent, once expressed, can be directly executed. The user states what they want; the AI does it. This model appears simple and efficient. It is also structurally unsafe.

Intent, as expressed by an individual, carries no inherent social context. It reflects personal desire, personal history, and personal framing. It does not carry information about whether that desire is consistent with social norms, ethical standards, legal constraints, or the wellbeing of others.

When intent is transmitted directly to a powerful AI execution layer, the gap between individual desire and social acceptability is not bridged — it is ignored. The result is a system that is responsive to the individual but unaccountable to society.

Principle: Intent without interpretation is not a command. It is an unvalidated signal.

The Velsanet architecture addresses this gap structurally. Intent does not travel directly to

execution. It passes through two mandatory checkpoints — PAI and AAI — each of which enforces a distinct category of validation before any action is authorized.

3. The Three-Layer AI Architecture as a Safety Chain

The three-layer AI architecture is not a pipeline. It is a safety chain. Each link in the chain is a structural boundary that cannot be bypassed.

3.1 PAI: The Personal Interpretation Layer

PAI is the AI that belongs to the individual. It is provisioned at the personal level and accumulates the individual's history, preferences, values, and behavioral patterns over time. Its function is not to execute intent but to interpret it.

When an individual expresses an intent, PAI does not ask "how do I fulfill this?" It asks: "what does this person actually mean, in the context of who they are and how they have acted before?" PAI transforms a raw intent signal into a structured, contextualized request — one that reflects not just what was said, but what was meant.

PAI cannot act on behalf of the individual. It can only represent the individual's interpreted intent to the AAI layer. This is a structural constraint, not a policy restriction.

Principle: PAI is the individual's interpreter, not their executor. It gives form to intent; it does not fulfill it.

3.2 AAI: The Social Validation Gateway

AAI is the agent layer. It receives interpreted intent from PAI and evaluates it against a set of social, ethical, legal, and policy constraints. AAI does not evaluate whether the intent is technically feasible. It evaluates whether the intent is socially acceptable.

If PAI's request is inconsistent with prevailing norms — if it violates ethical standards, conflicts with legal frameworks, or exceeds the scope of what is socially sanctioned — AAI refuses it. The request does not proceed to AsAI. The individual receives no execution. There is no override mechanism available to the individual.

AAI operates at a level above the individual but below the global AI layer. It is coordinated across a region or domain, reflecting the social norms of that context. Different AAI instances may apply different standards in different governance jurisdictions — consistent with the sovereignty model defined in Velsanet Network AI and Global Governance Architecture White Paper #18.

Principle: AAI is the gateway of social accountability. No intent reaches AsAI without passing through it.

3.3 AsAI: The Execution Layer That Cannot Be Directly Reached

AsAI is the most powerful AI layer in the Velsanet architecture. It operates at the scale of infrastructure, coordinating across multiple AAI instances, managing resources at the network level, and executing the actions that individual AI layers cannot perform alone.

AsAI has no direct relationship with any individual. It does not know who the individual is. It does not receive requests from individuals. It receives only validated, authorized requests from AAI agents — requests that have already passed through PAI interpretation and AAI social validation.

This is not a permission system. It is a structural fact. The architecture provides no mechanism by which an individual can address AsAI directly. The path does not exist.

Principle: AsAI is structurally unreachable by individuals. There is no

path, no override, no escalation.

4. Why Direct Access to AsAI Must Be Structurally Impossible

The impossibility of direct individual access to AsAI is not a restriction placed on users. It is a property of the architecture that protects both the individual and society.

Consider what direct access would mean. An individual, with no intermediary, could instruct the most capable AI layer in the network to act on their behalf. The individual's intent, uninterpreted, unvalidated, and unaccountable, would reach an execution layer of significant power.

The consequences of this design are not hypothetical. They follow structurally from the combination of individual intent and powerful execution:

- Individual intent is not inherently aligned with social good. It reflects personal interest, which may conflict with the interests of others.
- Individual intent is not inherently informed. It may be based on incomplete information, misunderstanding, or manipulation.
- Individual intent is not inherently stable. It may change, contradict itself, or be expressed in error.

When powerful execution is coupled directly to unvalidated individual intent, the system becomes an amplifier of individual error, bias, and malice. The structural solution is not to make AsAI smarter about detecting bad intent — it is to ensure that AsAI never receives unvalidated intent in the first place.

Principle: Safety is not achieved by making AI more discerning. It is achieved by ensuring that what reaches AI has already been validated.

5. How AsAI Grows: Collective Validation, Not Individual Demand

AsAI is not static. It evolves over time, expanding its capabilities and refining its models. But the mechanism of its growth is structurally constrained in the same way as its access.

AsAI does not grow in response to individual demand. It grows in response to the aggregated, validated requests of many AAI agents. When a pattern of socially validated requests recurs across many agents, in many regions, over time, AsAI updates itself to serve that pattern more effectively.

This design has three important consequences:

- AsAI's capabilities reflect collective social need, not individual desire. The most powerful AI layer in the network evolves to serve what society has validated, not what any single user has requested.
- AsAI's growth is observable and accountable. Because all inputs to AsAI pass through AAI, the record of what shaped AsAI is a record of socially validated requests — not a black box of individual interactions.
- AsAI cannot be shaped by manipulation. An individual cannot, through repeated or forceful requests, cause AsAI to develop capabilities that AAI would not approve. The validation layer is structurally interposed between individual intent and AsAI evolution.

Principle: AsAI grows through collective intelligence, not individual demand. Its evolution is governed by social consensus.

6. Safety by Structure vs. Safety by Rule

The dominant approach to AI safety today is rule-based. Developers publish usage policies. Governments propose regulations. Training processes include alignment objectives. These are all rules — statements about what the system should or should not do.

Rules have a fundamental weakness: they can be circumvented. Usage policies can be violated. Regulations can be evaded. Alignment training can be jailbroken. The rule-based approach to safety is in a permanent race against those who seek to circumvent it.

Structural safety operates on a different principle. A structural safety constraint does not tell the system what not to do. It makes certain actions architecturally impossible. There is no rule to circumvent because there is no path to follow.

The comparison is precise:

- Rule-based safety: "You must not send unvalidated intent to the execution layer." — This can be violated.
- Structural safety: "There is no mechanism by which unvalidated intent can reach the execution layer." — This cannot be violated.

Velsanet's three-layer AI architecture embodies structural safety. The impossibility of direct individual access to AsAI is not enforced by a rule. It is a consequence of the architecture itself.

Principle: Structural safety cannot be jailbroken. What does not exist cannot be bypassed.

7. Comparison with Global AI Governance Standards

The Velsanet structural safety model can be understood most clearly in contrast with existing global AI governance frameworks. Each of these frameworks represents a serious attempt to address AI safety — and each shares a fundamental limitation that Velsanet's architecture is designed to overcome.

7.1 EU AI Act (2024)

The EU AI Act classifies AI systems by risk level — unacceptable, high, limited, and minimal — and imposes compliance requirements on each category. High-risk systems must meet standards for transparency, human oversight, and data governance before deployment.

Relationship to Velsanet: The EU AI Act is a rule-based framework. It defines what AI systems must not do and what conditions they must satisfy. Compliance is verified through audits and certifications — external checks applied after the system is built. A system can pass certification and still be circumvented through prompt manipulation, adversarial inputs, or misuse by authorized users. Velsanet's structural approach makes certain categories of misuse architecturally impossible, not merely prohibited.

The EU AI Act tells AI what not to do. Velsanet makes certain actions structurally undoable.

7.2 NIST AI Risk Management Framework (AI RMF 1.0, 2023)

The NIST AI RMF provides a voluntary framework for organizations to manage AI-related risks. It defines four core functions — Govern, Map, Measure, and Manage — and offers guidance on implementing each across the AI lifecycle.

Relationship to Velsanet: The NIST framework is organizational, not architectural. It describes processes and practices for risk management, but does not prescribe structural properties that the AI system itself must possess. Velsanet's safety properties are not organizational choices — they are invariants of the architecture. They apply uniformly regardless of which organization deploys the system.

NIST AI RMF describes how organizations should manage AI risk. Velsanet embeds risk management into the architecture itself.

7.3 IEEE Ethically Aligned Design (EAD)

The IEEE Ethically Aligned Design initiative articulates principles for the ethical development of autonomous and intelligent systems. It addresses values such as human wellbeing, accountability, transparency, and the avoidance of misuse.

Relationship to Velsanet: IEEE EAD operates at the level of design principles and recommendations. It provides guidance for how engineers and organizations should think about ethics in AI development. It does not, however, specify structural mechanisms that enforce those principles in deployed systems. Velsanet translates the principle of accountability into a structural invariant that cannot be overridden.

IEEE EAD articulates ethical principles for AI. Velsanet operationalizes accountability as a structural property.

7.4 ITU-T Focus Group on AI for 5G / IMT-2030 (FG-AI4NN)

The ITU-T Focus Group on AI for Neural Networks and future networks has produced standards and recommendations addressing the integration of AI into telecommunications infrastructure. This work is directly relevant to network-level AI governance — the domain in which Velsanet operates.

Relationship to Velsanet: ITU-T's work on network AI focuses primarily on functional integration: how AI can be used to manage, optimize, and operate network infrastructure. Velsanet's PAI-AAI-AsAI architecture provides a structural model for governing individual-to-network-AI interaction that could inform future ITU-T standardization work on AI governance in IMT-2030 networks.

ITU-T FG-AI4NN addresses network AI integration. Velsanet proposes a structural governance model for individual-to-AI interaction that extends and complements this work.

7.5 Summary Comparison

The following table positions each framework against Velsanet across four dimensions:

Framework	Approach	Enforcement	Circumventable?
EU AI Act	Rule-based	External audit	Yes
NIST AI RMF	Process-based	Voluntary	Yes
IEEE EAD	Principle-based	Guidance only	Yes
ITU-T FG-AI4NN	Standards-based	Recommendation	Yes
Velsanet WP21	Structure-based	Architectural	No

The distinguishing property of Velsanet's approach is the final column. Every existing framework produces constraints that are, in principle, circumventable — because they are applied to a system that is not itself structured to prevent circumvention. Velsanet's structural safety properties are not constraints applied to the system. They are properties of the system.

8. The Complete Causal Chain

The following sequence traces the full path from individual intent to AI-mediated action in the Velsanet architecture:

1 Individual expresses intent

The individual communicates a desire, goal, or request. This expression is raw — it carries personal context but no structural validation.

2 PAI interprets intent

PAI applies the individual's accumulated history, values, and patterns to transform the raw expression into a structured, contextualized request. PAI does not execute; it interprets.

3 AAI validates the request

AAI evaluates the interpreted request against social, ethical, legal, and policy constraints. If the request is consistent with prevailing norms, it is authorized. If not, it is refused. No further steps occur.

4 AsAI executes the authorized request

AsAI receives only authorized requests from AAI. It executes at network scale, coordinating resources and actions that individual layers cannot perform. It has no knowledge of the individual whose intent originated the chain.

5 AsAI evolves from aggregated validated patterns

Over time, AsAI updates itself based on the aggregate of AAI-validated requests. Its evolution reflects collective social need, not individual demand.

Steps 1 through 3 are mandatory for every action. There is no shortcut. There is no escalation path. There is no administrator override available to individuals.

9. Summary

This white paper establishes the following principles as architectural invariants of the Velsanet AI safety model:

- Intent without interpretation is not a command. PAI is the mandatory first checkpoint — transforming raw individual intent into a structured, contextualized request.
- Social validation is not optional. AAI is the mandatory second checkpoint — evaluating interpreted intent against social, ethical, legal, and policy norms before any action is authorized.
- Direct individual access to AsAI is structurally impossible. There is no mechanism, no override, and no escalation path by which an individual can address AsAI without passing through PAI and AAI.
- AsAI evolves from collective validation, not individual demand. Its growth reflects what society has authorized, not what any individual has requested.
- Structural safety cannot be circumvented. A rule can be broken; an architectural impossibility cannot.
- Safety is a design property, not a policy property. It must be embedded in the structure of the system at the time of its design — not applied as an external constraint after the fact.
- All existing global AI governance frameworks — EU AI Act, NIST AI RMF, IEEE EAD, ITU-T FG-AI4NN — operate through constraints applied to AI systems. Velsanet operates through structural properties of the AI system. The distinction is the difference between a rule and an invariant.

The Velsanet three-layer AI architecture does not make AI safer by making it smarter about

detecting bad intent. It makes AI safer by ensuring that unvalidated intent never reaches the execution layer. The structure is the safety.

References

Velsanet White Papers

- Velsanet AI White Paper #08 v1.3 — AI Architecture Overview
- Velsanet Three-Layer AI System White Paper #09 v1.0 — PAI / AAI / AsAI Architecture
- Velsanet Network AI White Paper #10 v1.3 — Network-Level AI Integration
- Velsanet Foundation White Paper #12 v1.1 — Structural Critique of Internet Architecture
- Velsanet Identity White Paper #15 v1.0 — Network-Native Identity and Path Authority
- Velsanet Network AI and Global Governance Architecture White Paper #18 v1.0 — Q2-Q7 Governance
- Velsanet Node Intelligence and Optical Parallelism White Paper #20 v1.0 — Node-Level Intelligence

Global AI Governance Standards

- European Parliament and Council. Regulation (EU) 2024/1689 — Artificial Intelligence Act. Official Journal of the European Union, 2024.
- National Institute of Standards and Technology. AI Risk Management Framework (AI RMF 1.0). NIST AI 100-1, 2023.
- IEEE. Ethically Aligned Design: A Vision for Prioritizing Human Well-being with Autonomous and Intelligent Systems. First Edition, 2019.
- ITU-T Focus Group on AI for Future Networks (FG-AI4NN) — Deliverables on AI integration in telecommunications infrastructure, 2023-2024.
- ITU-R M.2160 (2023) — Framework and Overall Objectives of the Future Development of IMT for 2030 and Beyond.

Velsanet Architecture Group | Velsanet Research Institute (Proposed) | Republic of Korea

github.com/joa337/velsanet-whitepapers

VELSANET

White Paper No. 22

Velsanet H6-Based 6G RAN Architecture

Structure-Native Radio Access Without DU/CU

Version 1.0 | 2026

Velsanet Architecture Group | Velsanet Research Institute (Proposed) | Republic of Korea

github.com/joa337/velsanet-whitepapers

Abstract

This white paper defines the architecture by which Velsanet's H6 node — the hexahedral autonomous node at the physical and RAN mapping tier — receives 6G ultra-small cell base stations through a dedicated face connection via MOCT ribbon cable. The document establishes that this structure eliminates the functional need for Distributed Units (DU) and Centralized Units (CU) as defined in O-RAN and 3GPP architectures, because the structural properties of H6 face connection and Velsanet optical-native E2E replace those functions at the architectural level.

The core argument is architectural, not incremental: in Velsanet, the topology precedes addressing, and the physical connection precedes protocol. When a 6G base station connects to an H6 face via ribbon cable, it becomes an entry point into the optical domain. From that moment, all network behavior is governed by Velsanet's Layer-1 optical architecture. No intermediate processing layer — DU or CU — is required or meaningful.

1. Purpose of This Document

This white paper extends Velsanet Wired–Wireless Convergence White Paper #02 by defining the precise physical and structural relationship between the H6 node and the 6G ultra-small cell base station.

Specifically, this document addresses:

- The physical installation model: base station on utility pole, H6 node below, connected by 5m+ MOCT ribbon cable
- The H6 face assignment model: one face dedicated to base station connection

- The structural reason DU and CU become architecturally unnecessary
- The wired–wireless convergence boundary as defined by the H6 face
- The relationship of this architecture to existing 6G / IMT-2030 standardization efforts

Scope Note

This document does not define wireless-to-optical channel mapping parameters. Those physical implementation details — modulation alignment, timing, power levels — are deferred to hardware testing after Velsanet Research Lab establishment. The structural architecture described here is complete and does not depend on those parameters.

2. The H6 Node — Structure and Role

2.1 H6 in the Velsanet Polyhedral Hierarchy

Velsanet defines five node types based on polyhedral geometry: T4 (tetrahedron, 4 faces), H6 (hexahedron/cube, 6 faces), O8 (octahedron, 8 faces), D12 (dodecahedron, 12 faces), and I20 (icosahedron, 20 faces). Each polyhedral type encodes structural role, connectivity capacity, and position in the network hierarchy.

H6 occupies the physical and RAN mapping tier. As defined in Velsanet White Paper #20 (Node Intelligence and Optical Parallelism):

H6 represents the physical and RAN mapping tier: the stable anchoring layer that bridges wireless and optical domains.

H6 is an autonomous node. It possesses structural self-awareness — it knows its identity and its neighbors via Channel 1 of its ribbon cables — but it does not operate under AI layer coordination. H6 fulfills its role by existing and maintaining its physical connections. It does not route, prioritize, or respond to AI layer requests.

2.2 H6 Face Structure

The hexahedral geometry of H6 provides exactly 6 faces. Each face is a potential connection point. In the Velsanet architecture, face assignments follow structural role:

Face	Assignment	Description
Face 1	6G Base Station	Dedicated RAN connection face — MOCT ribbon cable from base station above
Face 2	O8 Upward	Connection toward O8 node — entry into Velsanet intelligent network layer
Face 3	Adjacent H6	Lateral connection to neighboring H6 node
Face 4	Adjacent H6	Lateral connection to neighboring H6 node
Face 5	Adjacent H6	Lateral connection to neighboring H6 node
Face 6	Reserved / Expansion	Available for additional base station or future structural extension

3. Physical Installation Model

3.1 Utility Pole Deployment

The H6-based 6G RAN deployment model is designed for ultra-small cell density in urban environments. The physical installation follows a two-point vertical model:

- 6G base station unit installed at the top of the utility pole — antenna exposure, wireless coverage
- H6 node installed at a lower point on the same pole, or at ground level / below-grade enclosure — structural connection point, optical domain entry
- MOCT ribbon cable (5 meters or more, factory pre-attached) runs vertically from the base station down to the H6 node face

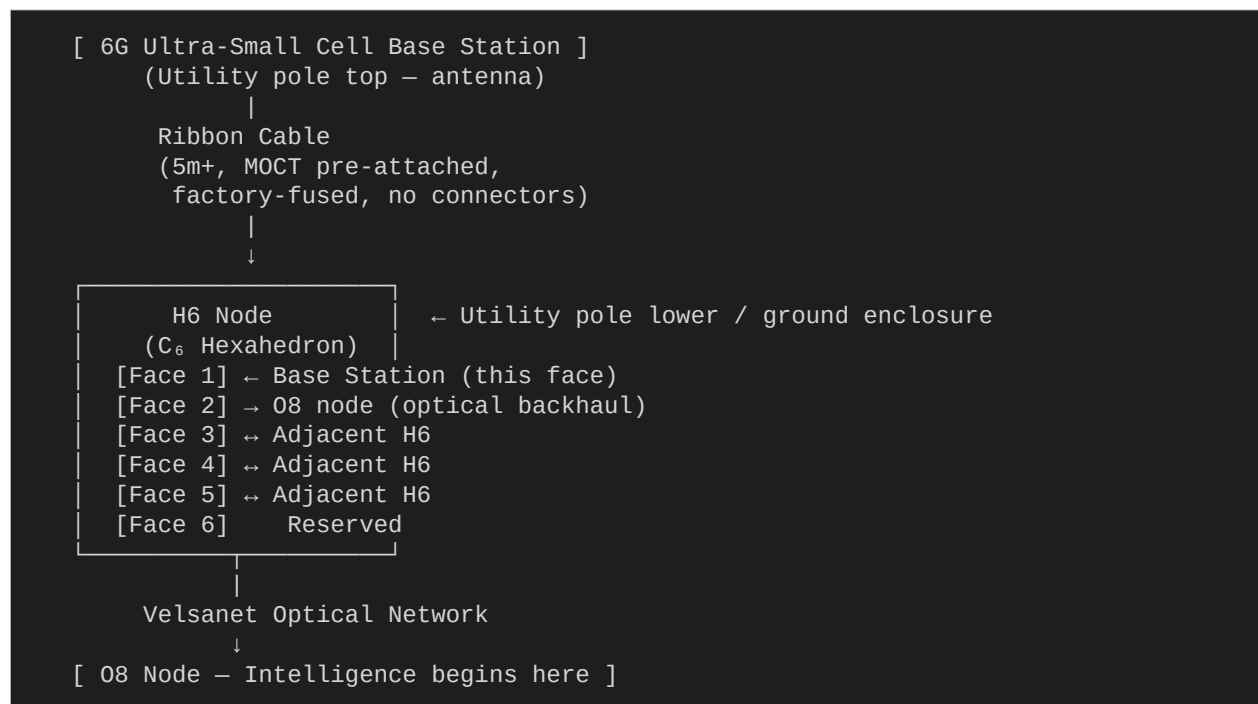

3.2 MOCT Ribbon Cable Properties

The ribbon cable connecting the base station to the H6 face is a MOCT (Multi-Optical-Core Transceiver) ribbon cable as defined in Velsanet White Paper #03. Its key physical properties in this deployment context are:

- Factory pre-attached — fused at manufacture, shipped as an inseparable extension of the base station unit
- Minimum length 5 meters — sufficient to span the vertical distance from pole top to H6 node below
- No connectors — zero insertion-loss variation, zero contamination risk, no mechanical wear
- Fixed, non-branching — one ribbon, one H6 face; no patch panels, no splitters
- 8 physical channels per optical core — Channel 1 reserved for sensing, control, and structural identity bootstrap; Channels 2–8 for data

Physical Design Principle

The 5-meter ribbon cable is not a specification chosen for convenience. It reflects the MOCT architecture's elimination of connectors. In conventional optical systems, cable length is constrained by connector placement. In Velsanet, the cable is the connection — it runs exactly as far as the physical gap between base station and H6 node requires, with no intermediate break points.

3.3 Urban Ultra-Small Cell Density

6G radio frequency bands (sub-THz, mmWave) require cell radii of tens of meters. This demands high-density base station deployment across urban environments. The H6 utility-pole model is structurally compatible with this density requirement:

- Every utility pole becomes a potential RAN node — no new civil infrastructure required
- H6 nodes connect laterally to adjacent H6 nodes via remaining faces — forming a ground-level mesh that mirrors the aerial antenna grid
- T4 nodes (personal/device-level) connect to the nearest H6 — preserving the rhizome origin principle of free, decentralized connection

4. Why DU and CU Are Not Required

4.1 What DU and CU Do in O-RAN

In the O-RAN and 3GPP architecture for 5G and proposed 6G, the radio access network is functionally split into three units:

- Radio Unit (RU) — antenna, RF processing, low-level PHY
- Distributed Unit (DU) — higher PHY, MAC, RLC — typically near the radio
- Centralized Unit (CU) — PDCP, RRC, session management — typically in the cloud or regional data center

This functional split exists because the underlying transport — IP/Ethernet — cannot guarantee deterministic end-to-end behavior. The DU and CU exist to manage packet scheduling, retransmission, session state, and routing across a network that does not provide structural guarantees. They are software abstractions compensating for physical-layer uncertainty.

4.2 What Replaces Them in Velsanet

When a 6G base station connects to an H6 face via MOCT ribbon cable, the following structural properties immediately apply:

- The connection is physically fixed — one ribbon, one face, zero ambiguity
- Channel 1 activates automatically — device authentication, physical alignment verification, structural identity exchange — without any external controller
- An individual E2E optical path is created — one device, one optical core, deterministic from base station to destination
- Handover is managed by V-MCU through overlapped E2E — the new E2E is pre-created before the old one is released, with zero packet loss
- All higher-layer network behavior is governed by Velsanet's structural topology — O8 nodes handle intelligence upward

Architectural Principle

DU and CU are not removed from Velsanet because they were made more efficient. They are absent because the problems they solve do not exist in a topology-first, optical-native architecture. Packet scheduling is unnecessary when each device has a physically isolated optical core. Session management is structural when E2E paths are created and released by topology, not by software state machines.

4.3 Function-by-Function Comparison

Function	O-RAN DU / CU	Velsanet H6
Packet scheduling	DU — software scheduler	Not required — each device has isolated optical core
PHY/MAC processing	DU — higher PHY, MAC, RLC layers	H6 face + MOCT — structural optical mapping
Session management	CU — PDCP, RRC state machines	E2E path creation/release by topology (V-MCU)
Routing / forwarding	CU — IP routing, GTP tunneling	Velsanet E2E — no routing protocol required
Handover coordination	DU+CU — X2/Xn interface signaling	V-MCU — overlapped E2E, zero packet loss
Fronthaul / midhaul	eCPRI / F1 interface over Ethernet	MOCT ribbon cable — direct face connection
Backhaul	IP/MPLS transport network	Velsanet optical backbone via O8 upward

5. The Wired–Wireless Convergence Boundary

5.1 Wireless as Entry Point, Not Network

Velsanet Wired–Wireless Convergence White Paper #02 establishes the foundational principle:

Wireless access in Velsanet is not a network, but an entry point into the optical domain. The wireless signal is received at the radio unit. The signal is immediately mapped into an optical core. From that moment onward, the communication is handled entirely by Velsanet's Layer-1 optical architecture.

The H6 face connection makes this principle physically concrete. The base station is the wireless domain. The H6 face is the convergence boundary. The MOCT ribbon cable is the crossing point. Everything that happens after the ribbon cable enters the H6 face is Velsanet — optical, structural, deterministic.

5.2 The Convergence Boundary Is Physical

In O-RAN, the convergence boundary between wireless and wired domains is a software interface — eCPRI, F1, N2/N3 — defined by protocol specifications that can be updated, versioned, and negotiated. The boundary is logical, not physical.

In Velsanet, the convergence boundary is the H6 face. It is a physical surface. The ribbon cable either connects to it or does not. There is no protocol negotiation at the boundary because the structural identity is established by Channel 1 of the ribbon cable before any data flows. The boundary is not a handshake — it is a physical fact.

5.3 What the H6 Node Does Not Do

Understanding H6's role requires clarity about what it explicitly does not do. H6 is an autonomous node. It does not:

- Coordinate across multiple peers
- Prioritize optical paths
- Respond to requests from AI layers (PAI, AAI, AsAI)
- Perform packet processing of any kind
- Manage session state
- Implement any wireless protocol (LTE, NR, 6G NR)

H6 exists and maintains its connections. The base station sends wireless signals. The ribbon cable carries them into the H6 face. The H6 maps them into optical cores. That is the complete function.

6. Mobility Management — The O8-Centered System

6.1 Mobility as a System, Not a Node Function

Mobility management in Velsanet is not a function performed by a single component. It is a system behavior that emerges from the coordinated operation of four structural elements: the H6 node, the O8 node, the V-MCU, and the device Identity. Each element has a distinct and non-overlapping role. None of them alone manages mobility — the system does.

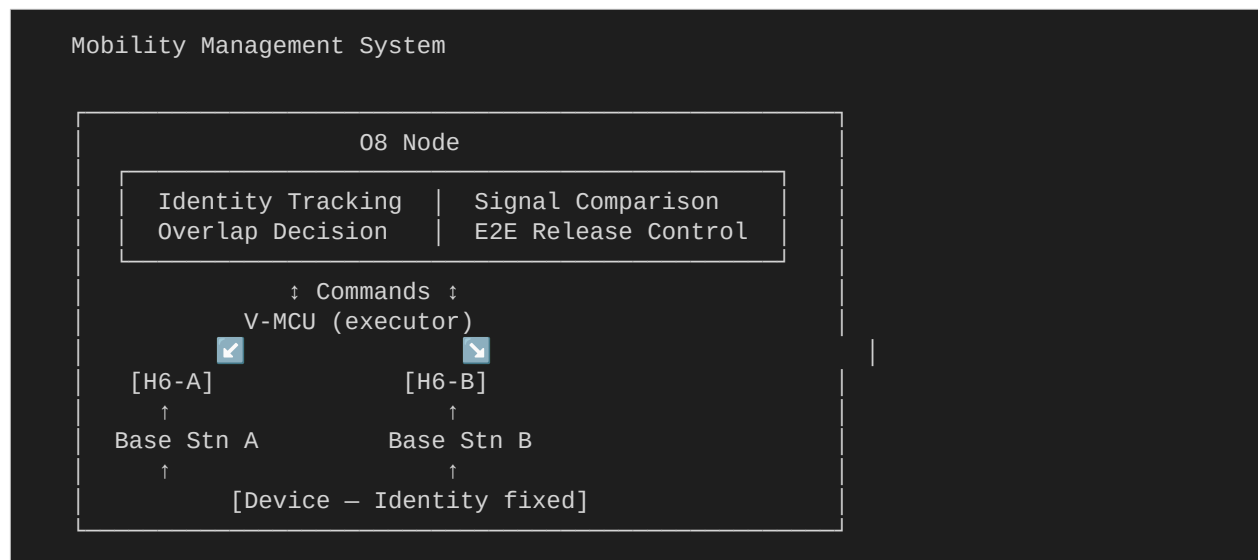

6.2 Why O8 Is the Mobility Decision Point

H6 is an autonomous node. It knows itself and its immediate neighbors. It cannot compare signal quality across multiple H6 nodes, cannot track a device across cells, and cannot decide when to pre-create or release an E2E path. H6 fulfills its role by existing — not by deciding.

O8 is the first node tier at which intelligence is structurally assigned. O8 can simultaneously observe multiple H6 nodes connected to it, compare their states, and issue coordinated commands through V-MCU. This is precisely the capability that mobility management requires.

Mobility decision authority therefore belongs to O8 — not because it was assigned by convention, but because the structural properties of O8 are the minimum required for mobility judgment.

6.3 Identity-Based Device Tracking

Every device that connects to Velsanet over a wireless interface carries a Velsanet Identity as defined in White Paper #15. The Identity is a network-native, structurally bound identifier — it does not change when the device moves, changes access point, or changes network layer.

When a device connects to a base station attached to H6-A, O8 records:

- Device Identity → H6-A face → optical core assignment
- Signal state via Channel 1 monitoring
- E2E path status (Active / Standby / Overlapping)

As the device moves, O8 tracks the Identity continuously. The Identity is the anchor. The H6 attachment point is the variable. Mobility is the management of that variable — without ever losing the Identity binding.

6.4 Overlapped E2E — The Mechanism of Zero-Loss Handover

The default handover mode in Velsanet is make-before-break, implemented through Overlapped E2E. The sequence is:

1	Device approaches H6-B coverage area. O8 detects signal presence on H6-B via Channel 1 monitoring.
2	O8 instructs V-MCU to pre-create a new E2E on H6-B for the same device Identity. H6-A E2E remains Active.
3	Both E2Es coexist — Overlapping state. O8 compares signal quality from both H6-A and H6-B simultaneously.
4	When H6-B signal is confirmed stable and H6-A signal is degrading, O8 instructs V-MCU to migrate traffic to H6-B E2E.
5	H6-B E2E becomes Active. H6-A E2E transitions to Terminating state and is released.
6	Identity binding is preserved throughout. No packet loss. No re-authentication. No session interruption.

6.5 Signal Selection — Choosing the Better Path

When a device is located between two H6 nodes — within coverage of both — O8 performs continuous signal comparison. This is not a handover event. It is ongoing signal selection: O8 observes Channel 1 data from both H6-A and H6-B and maintains the E2E on the structurally stronger path.

Signal selection operates as follows:

- Both H6-A and H6-B report Channel 1 status to O8 continuously

- O8 evaluates signal quality against predefined stability thresholds
- If H6-A is stronger: H6-A E2E remains Active, H6-B E2E held in Standby
- If H6-B becomes stronger and stable: O8 triggers make-before-break sequence
- The device experiences no disruption — the selection is network-side

This is structurally distinct from conventional handover: the device does not initiate, negotiate, or even detect the selection. The network selects on behalf of the Identity.

6.6 Role Boundaries Within the Mobility System

Component	Role in Mobility	Does NOT Do
H6 Node	Physical anchor — receives base station signal via ribbon cable face	Decision-making, signal comparison, E2E management
O8 Node	Mobility decision authority — Identity tracking, signal comparison, overlap control, E2E release command	Physical optical switching, direct device interaction
V-MCU	Execution layer — creates, activates, and releases E2E paths on O8 instruction	Deciding when to handover, comparing signal quality
Device Identity (WP15)	Persistent anchor — remains bound throughout movement, never re-authenticated on handover	Initiating or detecting handover

6.7 Mobility Across Multiple O8 Domains

When a device moves beyond the coverage area of a single O8 node — crossing into an adjacent O8 domain — mobility management escalates to the D12 layer (AAI). The O8-to-O8 transition follows the same Overlapped E2E principle, but coordination is handled by the D12 node above both O8 nodes.

This is consistent with the Velsanet hierarchical intelligence model: each layer manages mobility within its structural authority. O8 manages H6-to-H6 transitions. D12 manages O8-to-O8 transitions. The Identity remains bound throughout all levels of transition.

7. Comparison with 5G RAN Architecture

7.1 Structural Difference — One Principle

The fundamental difference between 5G and Velsanet H6-based 6G RAN is not a matter of speed, capacity, or efficiency. It is a matter of architectural class. 5G compensates for the limitations of packet-switched transport through software layers. Velsanet eliminates those limitations by replacing the transport model entirely.

5G is a system where software compensates for hardware limitations. Velsanet is a system where topology is the network function.

7.2 Architecture Side by Side

5G O-RAN:
 Base Station (RU) --> DU --> CU --> Core Network
 [RF processing] [PHY/MAC] [Session] [EPC/5GC]
 Each step: software processing, protocol translation, latency

Velsanet H6:
 Base Station --> Ribbon Cable --> H6 Face --> Optical Core --> Velsanet Network
 [RF] [5m MOCT] [boundary] [E2E path] [O8 and above]
 No intermediate processing. No protocol layers. No latency accumulation.

7.3 Item-by-Item Comparison

Dimension	5G O-RAN	Velsanet H6-Based RAN
RAN Structure	RU / DU / CU / Core — 3-stage functional split	Base station / H6 face / optical core — single boundary
Transport Model	Packet switching over eCPRI / IP / Ethernet	Physically isolated optical core per device
Fronthaul / Backhaul	eCPRI fronthaul, F1 midhaul, N3 backhaul — three interfaces	MOCT ribbon cable (5m+) — one physical connection, no interfaces
DU / CU	Required — PHY/MAC processing, session management, routing	Not required — H6 face and optical E2E replace these functions structurally
Handover Mechanism	X2/Xn signaling — DU reports, CU approves, device re-connects	Overlapped E2E — O8 pre-creates new path, transitions silently
Device Role in Handover	Device measures signal, reports to network, executes re-connection	Device does nothing — network manages Identity on device's behalf
Authentication on Move	Re-authentication possible on handover — session re-establishment	No re-authentication — Identity is persistent, bound at manufacturing
Mobility Decision	Device + DU + CU collaborative signaling	O8 node — sole authority based on Channel 1 signal comparison
AI Integration	External overlay — AI added above the network as service layer	Structural — PAI/AAI/AsAI embedded in O8/D12/I20 node tiers
Signal Selection	Device-initiated measurement reporting to network	O8 continuous Channel 1 monitoring — network-side, device-transparent
Latency Source	Packet queuing + DU/CU processing + re-routing on congestion	Physical path only — no queuing, no processing, no routing decisions
Security Model	Cryptographic protocols at upper layers — physical path unauthenticated	Physical-layer structural trust via Channel 1 at connection time

7.4 Why the Difference Is Architectural, Not Incremental

The 5G functional split — RU, DU, CU — exists because IP-based transport cannot provide deterministic end-to-end behavior. DU compensates with local scheduling. CU compensates with session state management. The O-RAN open interface standardizes the compensation. None of this changes the underlying problem: packets compete, paths are logical, and reliability is probabilistic.

Velsanet does not improve upon this model. It replaces the premise. When each device has a physically isolated optical core from the H6 face to its destination, there is nothing to schedule, no session to manage, and no route to compute. The functions that DU and CU perform become structurally unnecessary — not because they were made faster, but because the conditions that created the need for them no longer exist.

This is the sense in which Velsanet and 5G O-RAN belong to different architectural classes. The primary distinction is that one architecture assumes packet-switched transport and builds compensating layers above it; the other assumes topology-first optical connectivity and finds no need for those layers at all.

8. Relationship to 6G and IMT-2030 Standardization

6.1 IMT-2030 Requirements and Velsanet

ITU-R M.2160 defines the framework and objectives for IMT-2030 (6G). Among its key requirements are sub-millisecond latency, extreme reliability, and AI-native network operation. The H6-based RAN architecture addresses these requirements structurally:

- Sub-millisecond latency — achieved by eliminating DU/CU processing layers and replacing packet-switched transport with physically isolated optical cores
- Extreme reliability — achieved by MOCT's connector-free, permanently fused ribbon cable architecture, eliminating the primary failure modes of conventional optical systems
- AI-native operation — achieved by Velsanet's three-layer AI structure (PAI/AAI/AsAI) embedded in O8 and above, operating on a topology that is structurally stable from the H6 layer upward

6.2 Position Relative to O-RAN

O-RAN Alliance has defined an open, disaggregated RAN architecture that separates RU, DU, and CU and standardizes interfaces between them. This is an evolutionary approach: it improves upon the closed, vendor-proprietary RAN of 4G/5G while retaining the fundamental IP/packet-switched transport model.

Velsanet's H6-based RAN is not an evolution of O-RAN. It is a structural alternative that replaces the transport model entirely. The RU–DU–CU functional split is an artifact of packet-switched transport requirements. When those requirements are eliminated by optical-native E2E, the split loses its justification.

This does not mean Velsanet is incompatible with 6G radio technology. The base station unit that connects to the H6 face can implement any 6G radio standard — sub-THz, mmWave, or any spectrum defined by ITU-R or 3GPP. The radio unit is external to Velsanet. Only the transport and network function begins at the H6 face.

6.3 Proposed Contribution to ITU-T SG13

This white paper provides architectural basis for the following addition to Velsanet's ITU-T SG13 contribution under Work Item B (Optical-Native E2E Connectivity):

The H6 hexahedral node, connected to a 6G radio unit via factory-fused MOCT ribbon cable, demonstrates that the RU–DU–CU functional split is not an inherent requirement of radio access network architecture. It is a consequence of packet-switched transport. In an optical-native, topology-first network, radio access is a face connection — structurally defined, physically permanent, and protocol-independent.

9. Summary

This white paper establishes the following architectural principles:

1. The 6G ultra-small cell base station connects to one face of the H6 node via MOCT ribbon cable (5m+, factory pre-attached, no connectors).
2. H6 is installed below the base station — on the utility pole or at ground level. The ribbon cable spans the vertical distance between them.
3. The H6 face is the convergence boundary between the wireless domain and the Velsanet optical domain. It is a physical surface, not a software interface.
4. When the ribbon cable enters the H6 face, Channel 1 activates automatically — structural identity is established without external coordination.
5. From the H6 face inward, all network behavior is Velsanet — optical, structural, deterministic. No DU or CU layer exists or is required.
6. DU and CU are absent not because they were optimized away, but because the problems they solve — packet scheduling, session management, routing — do not arise in an optical-native, topology-first architecture.
7. Intelligence is introduced from O8 upward. H6 is autonomous — it fulfills its role by existing and maintaining its connections.
8. Mobility management is a system behavior: O8 is the decision authority, V-MCU is the executor, H6 is the physical anchor, and device Identity is the persistent binding throughout movement.
9. Overlapped E2E is the default handover mode — make-before-break, zero packet loss, no re-authentication, no session interruption.
10. Signal selection is network-side: O8 continuously compares Channel 1 quality from adjacent H6 nodes and selects the stronger path on behalf of the device Identity.
11. Wireless-to-optical channel mapping parameters are not defined in this document. The structural architecture is complete. Physical implementation values will be determined through hardware testing after Velsanet Research Lab establishment.

References

- Velsanet Network White Paper #01 v2.0 — Network Architecture Overview

- Velsanet Wired–Wireless Convergence White Paper #02 v1.0 — Wired and Wireless Integration
- Velsanet Multi-Optical-Core Transceiver (MOCT) White Paper #03 v1.1 — MOCT Architecture
- Velsanet Three-Layer AI System White Paper #09 v1.0 — PAI / AAI / AsAI Architecture
- Velsanet Node Intelligence and Optical Parallelism White Paper #20 v1.0
- Velsanet Identity White Paper #15 v1.0 — Network-Native Identity and Path Authority
- Velsanet Path Lifecycle White Paper #17 v1.0 — Path Lifecycle Management
- Velsanet ITU-T SG13 Contribution — IMT-2030 Topology-First Architecture
- ITU-R M.2160 (2023) — Framework and Overall Objectives of IMT-2030
- ITU-T Y.3001 (2011) — Future Networks: Objectives and Design Goals
- O-RAN Alliance — O-RAN Architecture Description v7.0
- 3GPP TS 38.401 — NG-RAN Architecture Description

VELSANET

Structure-Native Network Architecture

White Paper #23

6G RU: Multi-User Physical Mapping Design

— Structure-Native Physical Path Direct Mapping (No-Switching) —

Document No.	Velsanet-RU-STR-2026-03
Date	March 2026
Author	Meta-Architect Song Chang-ho
Series	<h2>1. Hardware-Based Multi-Access Mechanism</h2> <p>This design eliminates software schedulers entirely. All multi-user signals are mapped to optical cores in real time through dedicated hardware logic — not through OS-level arbitration or packet queuing. The physical structure of the RU is the network.</p> <h3>1.1 Spatial Multiplexing and Slot Assignment (Spatial → Slot)</h3> <ul style="list-style-type: none"> • 8-Channel MIMO: Signals from multiple users collected at the antenna layer are spatially separated, producing 8 independent wireless streams. Each stream represents a distinct spatial direction — not a distinct user identity. • Time-Sensitive Gearbox: The 8 separated wireless data streams are fixed-mapped 1:1 onto 8 Physical Slots within a single optical core. No buffering occurs. No wait state exists. The mapping is deterministic and immediate. <div style="border: 1px solid #0070C0; padding: 5px; margin-top: 10px;"> <p><i>Design principle: The Time-Sensitive Gearbox is not a scheduler. It is a fixed hardware interconnect that aligns wireless stream timing to optical slot timing. Once a stream enters a slot, it exits the other end of the fiber at the speed of light with no intermediate logic.</i></p> </div> <h3>1.2 Sector-to-Core Physical Direct Link</h3> <ul style="list-style-type: none"> • Fixed Interconnect: The Coherent Optical Engine inside the RU is physically wired to transmit data from a specific sector exclusively onto a designated core (Core #N) within the 48-core MOCT ribbon. This wiring is established at manufacture — not configured at runtime.

- **Structure-Native:** The system does not compute who the user is. It routes data based solely on which sector the signal arrived from, onto a pre-assigned dedicated optical path. Identity is irrelevant; direction is everything.

"Physical infrastructure is the network's logical structure."

This is the foundational departure from conventional RAN design. Legacy systems identify users, schedule transmissions, manage sessions, and arbitrate across shared resources. In Velsanet Structure-Native RAN, none of these operations exist. The physical path is the only logic.

Figure 1 — RU Internal Architecture: Signal Flow (No-Software Path)

Velsanet-RU-STR-2026-03 · White Paper #23

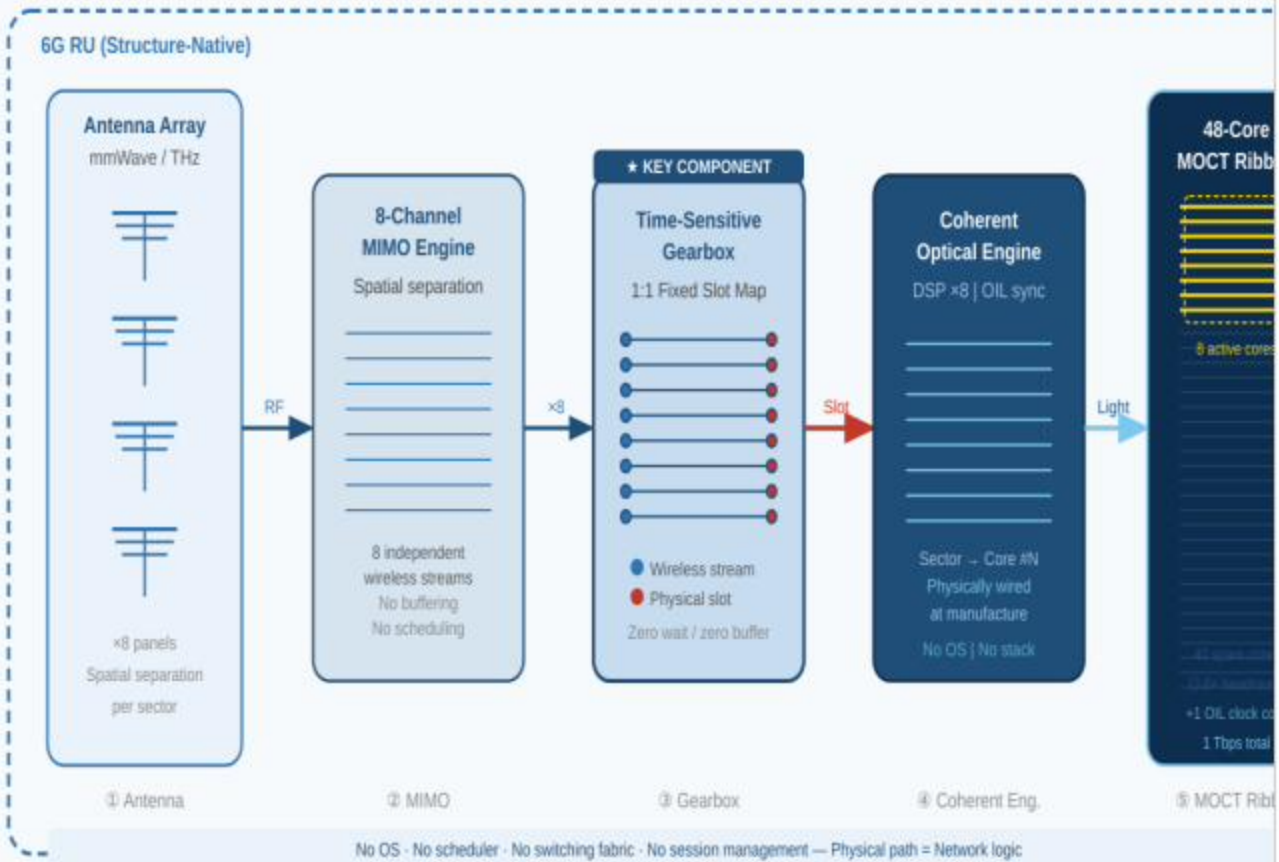

Figure 1 — RU Internal Architecture: Antenna → MIMO → Time-Sensitive Gearbox → Coherent Optical Engine → 48-Core MOCT Ribbon

2. Capacity and Scalability Design

Category	Design Specification	Note
Base Capacity	1 Tbps / core (8-channel)	High-density user absorption per single core

	aggregate)		
Structural Headroom	48-Core MOCT Ribbon	3.6x core surplus vs. subscriber count	
Dynamic Expansion	Spare Core Activation	Physical path extension on traffic surge	
Synchronization	Optical Injection Locking	Physical alignment of all user signals	

The 48-core MOCT ribbon provides a structural surplus ratio of 3.6x over Seoul's 12 million mobile subscriptions. This surplus is not waste — it is the physical substrate for future demand: IoT sensors, V2X channels, high-density video, and PAI-native machine coordination. When capacity is needed, spare cores are activated. No new civil works. No software reconfiguration. Physical paths are added.

Optical Injection Locking allocates 1 of 48 cores exclusively to clock distribution. H6 transmits the reference clock to RU via optical carrier. The RU's Coherent Optical Engine locks onto this signal and synchronizes all 8 DSP channels. Clock jitter is eliminated by physical propagation — not by packet-based correction algorithms.

3. Elements Structurally Eliminated

The following table summarizes the layers and mechanisms that conventional RAN architectures require and that Velsanet Structure-Native RAN does not implement. Elimination is architectural — not a configuration option.

Eliminated Element	Legacy Approach	Velsanet Structure-Native	
Software Scheduler	OS-level packet scheduling, queuing, priority arbitration	Eliminated — hardware-fixed sector-to-core mapping	
Switching Fabric	Electronic crossbar / forwarding table lookup	Eliminated — physical ribbon core pre-assigned at manufacture	
DU / CU Stack	Virtualized distributed/centralized unit software	Eliminated — structural path replaces logical layer	
Session Management	User identity computation, authentication per handover	Eliminated — direction-based physical routing, no identity check	
Clock Distribution	PTP / IEEE 1588 packet-based clock recovery	Eliminated — Optical Injection Locking via dedicated core	

The consequence of this elimination is absolute: no OS boot, no software fault surface, no scheduler latency, no session re-establishment on handover. The RU has no software state. It is a precision optical-wireless transducer — and nothing more.

network. It is a structured physical medium for intelligence.

5. Hardware Block Detailed Design Specification

This section defines the internal hardware architecture of the Velsanet 6G RU at the block level. Three functional blocks constitute the complete signal path from antenna to optical core: the Time-Sensitive Gearbox (TSG), the 48-Core MOCT Physical Interface, and the Optical Injection Locking (OIL) synchronization unit. Together they form a zero-software, hardware-native transduction chain.

5.1 Time-Sensitive Gearbox (TSG) — Core Mapping Logic

Function

Velsanet's design responsibility begins at the TSG input. RF processing — antenna, beam-forming, PHY, MAC, A/D conversion — is performed by the 6G RU and is outside Velsanet scope. The TSG receives 8-channel parallel digital baseband output from the 6G RU and performs a strictly 1:1 fixed mapping to 8 assigned optical slots. It contains no scheduling logic, no priority queue, no buffer management, and no software interrupt path. It operates as a pure hardware interconnect: signals enter at the RF/optical boundary and exit into the Coherent Optical Engine without any intermediate state.

Implementation

The TSG is implemented as a fixed-delay wiring fabric within a dedicated FPGA or custom ASIC. Each of the 8 input channels is hard-wired to a corresponding output lane through nanosecond-precision delay lines. The delay is matched across all 8 channels to within ± 50 ps to ensure slot alignment at the optical engine input. There is no clock domain crossing logic, no FIFO, and no reconfigurable routing plane. The mapping is physically determined at manufacture and cannot be altered in the field.

Internally, the FPGA fabric contains 8 independent parallel signal paths, each with a fixed propagation delay of less than 2 ns end-to-end. No time-division multiplexing occurs within the TSG: each channel occupies its dedicated physical path at all times.

Differentiation from Legacy RAN

Legacy RAN architectures employ OS-based packet queuing at the DU layer, introducing variable latency of 0.1–10 ms depending on scheduler load. The TSG eliminates this regime by replacing the scheduler with physical slot alignment. The latency contribution of the TSG is bounded by its fixed propagation delay — approximately 2–5 ns, versus 100,000–10,000,000 ns in software-scheduled systems.

5.2 48-Core MOCT Physical Interface

Physical Configuration

The MOCT interface consists of 48 single-mode optical fiber cores in a flat ribbon geometry. Core assignments are permanent and functionally differentiated:

Core #1 — Channel 1 (structural sensing and control). Device authentication, physical alignment verification, and self-awareness bootstrap per WP#03 and WP#20. Carries no user data.

Core #48 — Clock reference core (Optical Injection Locking). Carries a continuous-wave optical reference signal from H6 to RU. Carries no user data. See Section 5.3.

Cores #2–#47 — 46 active data cores. Each core is hard-wired to a specific sector signal output from the Coherent Optical Engine. The mapping is physically determined at manufacture.

Hard-Wired Sector-to-Core Assignment

The Coherent Optical Engine is physically wired such that each sector's optical output feeds exclusively into its pre-designated core. Sector A occupies Core #2–#17 (16 cores). Sector B occupies Core #18–#33. Sector C occupies Core #34–#47. This distribution is fixed in the photonic substrate at manufacture.

Structural Headroom: 3.6x Capacity Reserve

Against Seoul's subscriber density baseline, the 46 active data cores provide 3.6x the physical capacity required at peak load. When traffic demand increases, idle cores are activated by the optical engine without any software reconfiguration — no provisioning cycle, no software update, no network re-convergence.

5.3 Optical Injection Locking (OIL) — Physical Synchronization Unit

The Synchronization Problem in Conventional RAN

Conventional RAN synchronization relies on IEEE 1588 PTP or GPS-derived timing transmitted as packet payloads across IP/Ethernet networks. Because packets traverse queues, the timing signal is subject to variable latency from path asymmetry, queuing delay, and processing jitter. Residual clock jitter is typically 10–100 ns, with worst-case excursions exceeding 1 μ s under congestion. This jitter propagates directly into 6G modulation timing.

Operating Principle

OIL replaces the packet-based timing signal with a continuous-wave (CW) optical reference signal transmitted over Core #48. The H6 node emits a spectrally pure CW laser signal into Core #48. At the RU, the Coherent Optical Engine contains a slave laser whose cavity is optically coupled to Core #48. The slave laser undergoes injection locking: its oscillation frequency and phase are captured by the incoming reference wave, synchronizing the RU's optical engine to the H6 clock source at the physical level. No packet is transmitted. No timestamp is parsed. No algorithm computes a correction offset. The lock is established and maintained by the physics of optical resonance — specifically, the Adler equation governing injection locking bandwidth.

Synchronization Precision

Once injection lock is established, the RU slave laser maintains phase coherence with the H6 reference to within femtosecond (10^{-15} s) accuracy — four to five orders of magnitude better than packet-based PTP. The jitter of the synchronized clock is bounded only by the phase noise floor of the H6 master laser and the shot noise of the optical path, both deterministic physical constants.

Lock Acquisition Sequence

The OIL acquisition sequence proceeds entirely in hardware:

Step 1 — H6 powers on. Core #48 CW reference signal begins propagating immediately.

Step 2 — RU powers on. Slave laser detects CW signal on Core #48 within nanoseconds of first photon arrival.

Step 3 — Injection locking engages. Lock acquisition time is approximately 1–10 μ s.

Step 4 — Lock confirmed. RU optical engine transmits structural identity signal via Core #1 Channel 1 to H6. Self-awareness bootstrap completes per WP#20.

Step 5 — Data cores (Core #2–#47) activate. RU enters operational state. Total boot time under 100 ms, with no software initialization path.

Velsanet Clock Hierarchy

The OIL architecture extends vertically through the full Velsanet hierarchy: I20 → D12 → O8 → H6 → RU. The root clock source resides at the I20 tier, where a GPS-disciplined or atomic reference laser serves as the ultimate frequency standard. Each tier locks optically to its parent. No packet crosses the clock path at any level. The entire clock tree is a passive optical phenomenon propagating deterministically through fixed physical paths.

Environmental Stability

Thermal variation in the ribbon cable causes minor changes in fiber refractive index. Single-mode silica fiber exhibits a thermo-optic coefficient of approximately 10^{-5} /K, producing a phase shift of 0.1 rad/K over a 7 m path. The MOCT MEMS alignment layer (WP#03 Section 8.3) compensates for thermally induced mechanical displacement. Residual phase drift is absorbed within the injection locking bandwidth of the slave laser cavity (designed to exceed 1 GHz), making sub-Hz thermal drift negligible. Clock stability is maintained across -20°C to +60°C without active compensation circuitry.

6. Bill of Materials (BOM)

This section defines the complete material composition of the Velsanet 6G RU at the unit level. The BOM is organized into two sub-levels: RU internal components, and pole-site assembly including inter-node cabling. All ribbon cables are factory pre-attached and shipped as integral extensions of their respective nodes.

6.1 6G RU Internal BOM (per unit)

#	Assembly / Block	Component / Specification	Key Parameter	Qty
	RF Interface Requirements (6G RU Manufacturer Scope)			
1	RF Output Interface	8-channel MIMO output from 6G RU — per manufacturer spec (sub-THz/ mmWave). Velsanet defines the interface requirement only; antenna design is outside Velsanet scope.	8 independent RF output channels, sector-aligned	Per RU mfr.
2	TSG Input Interface Spec	Velsanet TSG requires: 8-ch parallel digital baseband input, channel-to-slot alignment per sector. RF processing (PHY, MAC, beam-forming) is the responsibility of the 6G RU manufacturer.	Interface boundary: digital baseband output of 6G RU to TSG input	1

	Time-Sensitive Gearbox (TSG)				
3	Fixed-Delay Wiring Fabric	FPGA / custom ASIC, 8 hard-wired parallel paths, no scheduler, no FIFO	Propagation delay < 2 ns, ± 50 ps channel match	1	
4	Slot Alignment Circuit	8-lane delay line, hardware-matched across all channels	Jitter < 50 ps end-to-end	1	
MOCT Physical Interface					
5	Coherent Optical Engine	Wireless-to-optical mapper, sector-to-core hard-wired	Core #2–#47 (46 data cores), 3.6x capacity reserve	1	
6	Slave Laser (OIL)	Injection-lockable laser cavity, coupled to Core #48	Lock bandwidth > 1 GHz, jitter < 1 fs post-lock	1	
7	Polymer Optical Core Layer	48-core polymer waveguide array, 8 fixed channels per core	Core #1=control, Core #48=clock, #2–#47=data	1	
8	Mechanical Contact Layer	Static micro-contacts, micron-level alignment, no moving parts	Vibration-resistant, zero operational power	1	
9	MEMS Alignment Layer	Silicon photonics matrix+ static MEMS, lithographic precision	Temp-invariant, -20°C to +60°C	1	
10	Pre-attached Ribbon Cable (RU)	48-core single-mode ribbon, factory-fused, no connectors	Length 7 m, permanently bonded	1	
Mechanical & Power					
11	Weatherproof Enclosure	IP67-rated outdoor housing, pole-top mount	Operating range -20°C to +60°C	1	
12	Pole Mounting Bracket	Clamp + tilt-adjust bracket for utility pole top	Pole diameter 80–150 mm	1	
13	Power Supply Unit	DC input or PoE++, surge protection, no active cooling	Power draw < 15 W per RU	1	

6.2 Pole-Site Assembly BOM (per pole)

#	Item	Specification	Segment / Role	Qty
1	6G RU (complete unit)	Per 6.1 BOM above, pole-top installation	Wireless endpoint — Seg A origin	1–3 / pole
2	H6 Node	C6 Hexahedron, 6-face, autonomous, installed at +2 m	RAN mesh anchor	1 / pole
3	MOCT Ribbon — H6 Face 1	48-core, 5 m, factory pre-attached to H6	Seg A — fused with RU cable	1 / pole

	4	MOCT Ribbon — H6 Face 2	144-core (12x12 stack), 5 m, factory pre-attached	Seg C — H6 to O8 uplink	1 / pole	
	5	MOCT Ribbon — H6 Face 3	48-core, 5 m, factory pre-attached	Seg B — H6 to adjacent H6 mesh	1 / pole	
	6	MOCT Ribbon — H6 Face 4	48-core, 5 m, factory pre-attached	Seg B — H6 to adjacent H6 mesh	1 / pole	
	7	MOCT Ribbon — H6 Face 5	24-core, 5 m, factory pre-attached	T4 downlink	1 / pole	
	8	MOCT Ribbon — H6 Face 6	48-core, 5 m, factory pre-attached	Reserved / expansion	1 / pole	
	9	Ribbon Fusion Splice Kit	Full-ribbon simultaneous fusion, field-grade	RU cable + H6 Face-1 splice (Seg A)	1 / pole	
	10	Underground Conduit Section	144-core armored ribbon, H6 to building wall entry	Seg C buried run	per m	
	11	Pole Ground Enclosure / Shroud	H6 protective housing, IP67, tamper-resistant	H6 installation enclosure at +2 m	1 / pole	
	<p><i>Note: All MOCT ribbon cables are factory pre-attached and non-detachable. Field installation involves only ribbon fusion splicing at designated splice points; no pluggable connectors exist in any Velsanet node interface. Quantities marked per m are determined by site survey at deployment time.</i></p> <p>White Paper #23 — Velsanet Architecture Group</p>					
Core Concept	Structure-Native physical path direct mapping, no software switching					
Reference Docs	WP #02, #03, #22 · Velsanet Architecture Compendium v1.0 (2026)					